



intro

The Avia B.534 was developed in 1934 as an extension of the B.34 fighter. In this incarnation, which was produced in small numbers for the Czechoslovak Air Force (the majority of which were attached to No.3 Fighter Regiment in Slovakia at the beginning of the Second World War), there were several engine/airframe combinations tried. The B.234 prototype served as the basis for the re-engined (Hispano Suiza 12 Ydrs for the original Avia R-29 radial) type that became the true B.534. This was the 1934 victor in a tender for a new standard fighter for the air force, and in June of that year, Avia received an order for an initial 34 aircraft. The orders accumulated to a total of 568 units, built in several production blocks.

Assessments of the aircraft are somewhat variable. At the time of its development, it was an aircraft that was technically sound and utilized progressive construction techniques, but by the time of the Munich Crisis, the technology was slowly but surely entering the realm of the obsolete. To top it off, the politics of the situation during the Crisis disallowed the chance of combat. The chance for combat missions to be flown didn't occur until a few years later, in 1941, in the services of the Slovak State, fighting for the side that had previously been the aggressor against which they were to stand. Slovak pilots flying the B.534 on the Eastern Front gained good results, and these can be viewed upon as being the climax of the career of the type. A year later, it was apparent that replacement by more modern types was necessary, and inevitable. Bulgarian attempts to combat Ploesti raiding B-24 Liberators with the B.534 was a failure, and the aging planes were not able to climb to the Liberator's operational altitudes. In Slovakia, as in Bulgaria, the type was destined for second line relegation.

Some of the remaining B.534s were destined for final operations within the Bulgarian Air Force in operations over Hungary in 1944, and with Slovakia during the several weeks long uprising against Germany (late August - early November 1944). During the Slovak National Uprising, the type was used primarily in the ground attack role, and one did manage a kill to become what is the last aerial victory of a biplane in history. It should be noted that the kill in question was that of a Hungarian transport. The fact remains that the Slovak National Uprising did end up being the swansong of the Avia B.534. Certainly, it can be said that due to the era and climate of the service of this aircraft, and the length of service it was able to achieve, the Avia B.534 has become one of the most profound symbols of Czechoslovak aviation history, a very positive symbol.

Our model was influenced by these facts, and what the type means to us. We developed the kit with diligence and scrutiny, employing the most modern manufacturing technology at our disposal. In that sense, we have something in common with the original developers of the type all those years ago, and we hope that this fact will make our tribute to this aesthetically pleasing type longer lasting than the older big brother.

úvodem

Avia B.534 vznikla v roce 1934 vývojem základního typu B.34. Z této konstrukce, která byla vyrobena v malé sérii pro československé letectvo (většina vyrobených strojů sloužila u Leteckého pluku 3 na Slovensku a později dolétala ve službách Slovenského státu na začátku 2. světové války), bylo odvozeno několik motorových variant. Z prototypu B.234 vznikla záměnou motoru (Hispano Suiza 12 Ydrs za původní hvězdicový Avia R-29) právě B.534. Ta zvítězila v roce 1934 v tendru vojenského letectva na novou standardní stíhačku, a v červenci 1934 dostala Avia první objednávku na 34 kusů. Objednávky byly postupně rozšiřovány až na konečných 568 kusů, vyrobených v několika výrobních blocích.

Hodnocení výkonů Avie B.534 je poněkud rozporné. Ač to byl stroj v době svého vzniku technicky jistě na výši doby a využíval progresivní konstrukční prvky, v době Mnichovské krize už pomalu, ale jistě zastarával. Vzhledem k politickým okolnostem navíc piloti nedostali příležitost zasáhnout do boje, k jehož vedení byli cvičeni a motivováni. Do skutečného boje se Avie dostaly až o několik let později, v roce 1941, ve službách Slovenských Vzdušných zbraní, tedy de facto na straně původního protivníka. Na Východní frontě předvedli slovenští piloti v kabinách Avíí dobré výkony, díky nimž lze nasazení na východě považovat za vrchol kariéry Avie B.534. O rok později už ale Avíím zvonila hrana, a přišel čas jejich náhrady modernějšími stroji.

Pokus Bulharů z roku 1943 o zásah proti americkým Liberatorům, útočícím na Ploesti, skočil jednoznačným neúspěchem. Avie nedokázaly ani vystoupat do operační výšky Liberatorů. Jak na Slovensku, tak v Bulharsku čekal Avie osud většiny vysloužilých stíhaček, přešly nejprve k bitevním úkolům a poté k pomocným rolím. Na několik zbylých Avíí čekal poslední boj, v rámci bulharského letectva při plnění bitevních úkolů v Maďarsku, na slovenské Avie pak několikátý denní vystoupení při protiněmeckém povstání na Slovensku. I zde převážně útočily na pozemní cíle, nicméně jedna z Avíí zaznamenala poslední sestřel dosažený tímto typem, a pravděpodobně vůbec poslední sestřel dosažený dvouplošníkem v dějinách. Je ovšem nutné dodat, že šlo o sestřel neozbrojeného dopravního letounu, což je záležitost, vzhledem ke všem okolnostem této události, poněkud diskutabilní. Službou v SNP se fakticky historie Avie B.534 uzavírá. Přes zmíněnou nepřízeň osudu se Avie B.534, díky délce své služby i historickému období, kdy ve službě byla, stala jedním ze symbolů československého letectva. A to symbolem jednoznačně pozitivním.

Náš model reflektuje všechny tyto skutečnosti. K jeho tvorbě jsme přistupovali velmi zodpovědně a nasadili jsme k tomu nejmodernější technické prostředky, které jsme měli k dispozici. Z tohoto hlediska jsme postupovali stejně, jako svého času firma Avia při konstrukci skutečného stroje, a nám nezbyvá než doufat, že náš model nebude ztrácet své přednosti stejně rychle, jako jeho velký vzor.

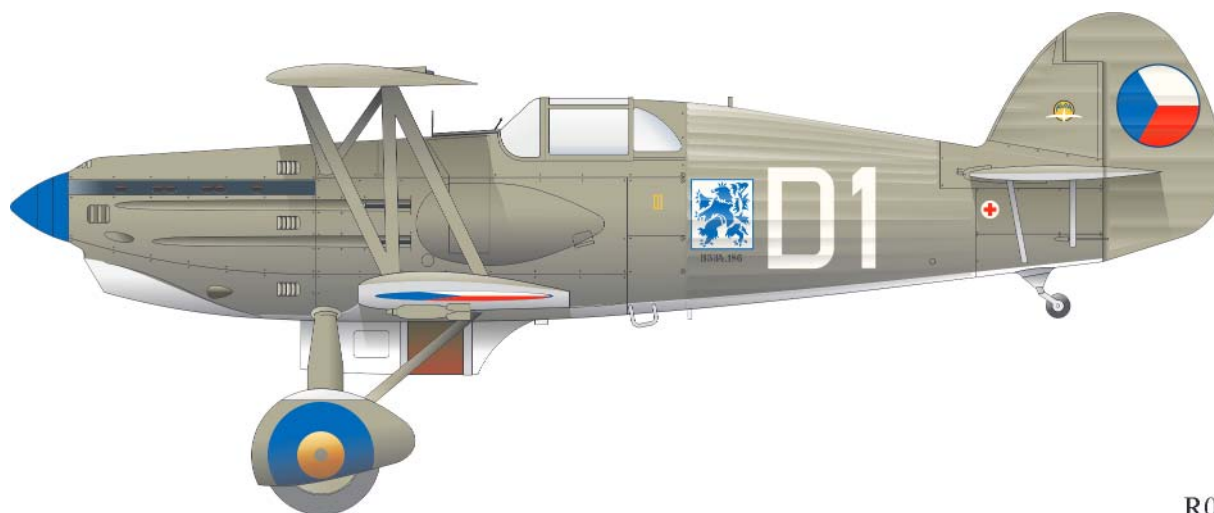

ATTENTION



UPOZORNĚNÍ



ACHTUNG



ATTENTION



注意



Carefully read instruction sheet before assembling. When you use glue or paint, do not use near open flame and use in well ventilated room. Keep out of reach of small children. Children must not be allowed to suck any part, or pull vinyl bag over the head.



Před započítím stavby si pečlivě prostudujte stavební návod. Při používání barev a lepidel pracujte v dobře větrané místnosti. Lepidla ani barvy nepoužívejte v blízkosti otevřeného ohně. Model není určen malým dětem, mohlo by dojít k požití drobných dílů.

INSTRUCTION SIGNS * INSTR. SYMBOLS * INSTRUKTION SINNBILDEN * SYMBOLES * 記号の説明

OPTIONAL
VOLBABEND
OHNOUOPEN HOLE
VYVRTAT OTVORSYMETRICAL ASSEMBLY
SYMETRICKÁ MONTÁŽREMOVE
ODŘÍZNOUTREVERSE SIDE
OTOČITAPPLY EDUARD MASK
AND PAINT
POUŽÍT EDUARD MASK
NABARVIT

PARTS



DÍLY



TEILE



PIÈCES



部品

A> 4 pcs.

7100 A

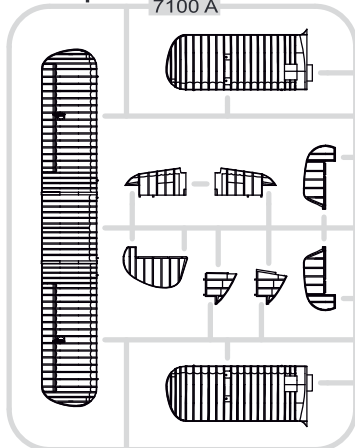

B>

PLASTIC PARTS

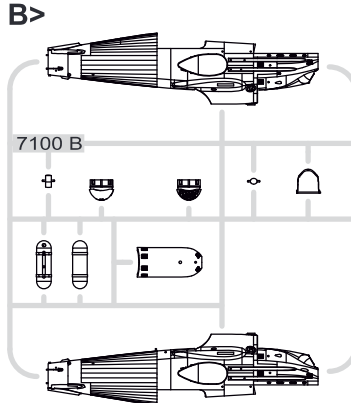

C>

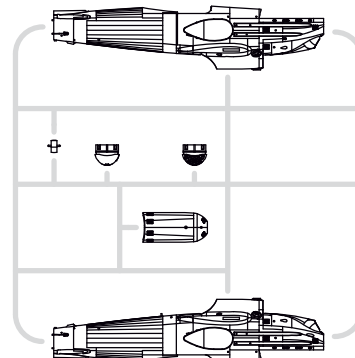

D>

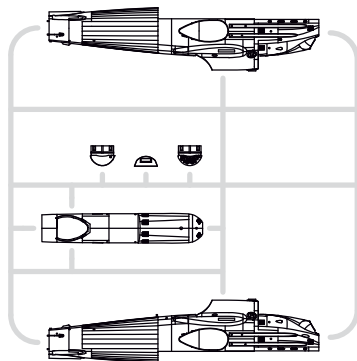

E> 4 pcs.

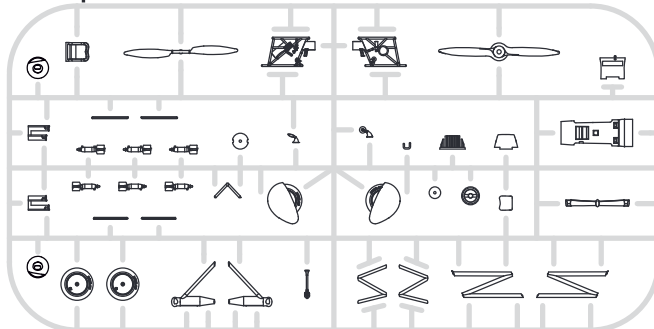

F> 2 pcs.

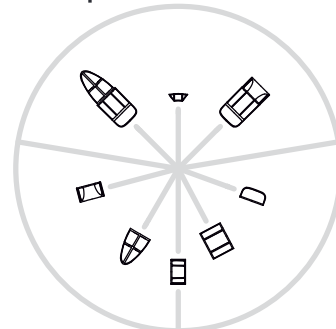

G>

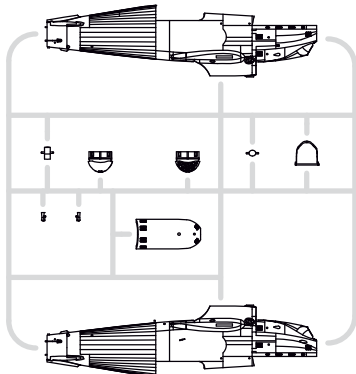
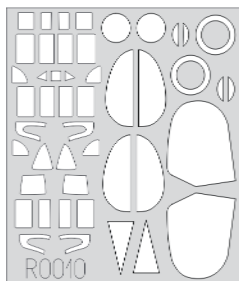
eduard
MASK

PE - PHOTO ETCHED DETAIL PARTS

4 pcs.

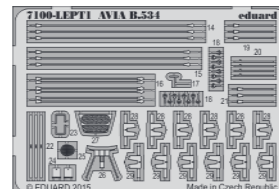
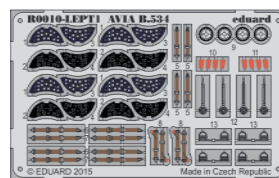

-Parts not for use. -Teile werden nicht verwendet. -Pièces à ne pas utiliser. -Tyto díly nepoužívejte při stavbě. - 使用しない部品

COLOURS



BARVY



FARBEN



PEINTURE



色

GSI Creos (GUNZE)		
AQUEOUS	Mr.COLOR	
H 3	C3	RED
H 4	C4	YELLOW
H 5	C5	BLUE
H 6	C6	GREEN
H 8	C8	SILVER
H 11	C62	FLAT WHITE
H 12	C33	FLAT BLACK
H 21	C69	OFF WHITE
H 28	C78	METAL BLACK

AQUEOUS	Mr.COLOR	
H 33	C81	RUSSET
H 37	C43	WOOD BROWN
H 42		BLUE GRAY
H 43	C100	WINE RED
H 47	C41	RED BROWN
H 51	C11	LIGHT GULL GRAY
H 53	C13	NEUTRAL GRAY
H 64	C17	DARK GREEN RLM71
H 77	C137	TIRE BLACK

AQUEOUS	Mr.COLOR	
H 80	C54	KHAKI GREEN
H 67	C118	LIGHT BLUE RLM65
H 303	C303	GREEN
H 413	C113	YELLOW RLM04
Mr.COLOR SUPER METALLIC		
SM01		SUPER FINE SILVER
Mr.METAL COLOR		
MC214		DARK IRON
MC215		COPPER

- B1 - MARKINGS 7-10, 13-18, 23-31
- C1 - MARKINGS 12, 20-22
- D1 - MARKINGS 1, 4-6, 11, 19
- G1 - MARKINGS 2, 3

B1 ? C1 ? D1 ? G1

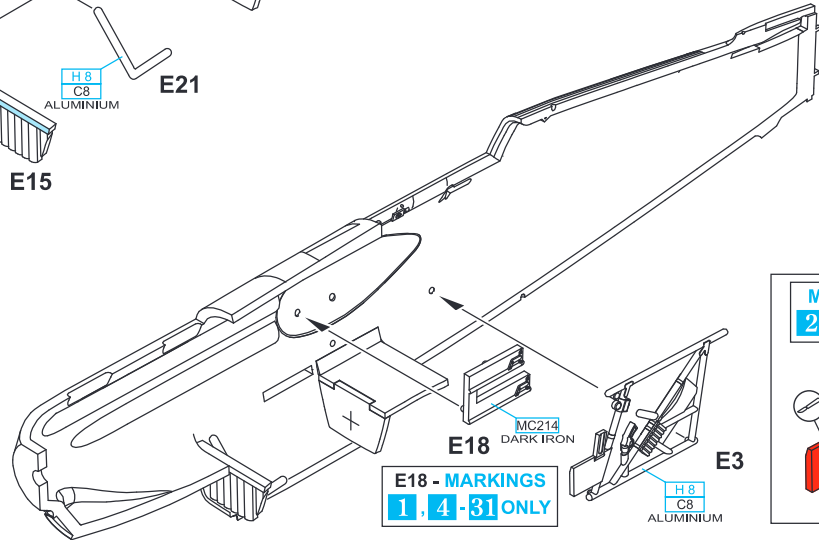
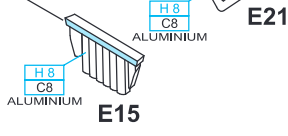
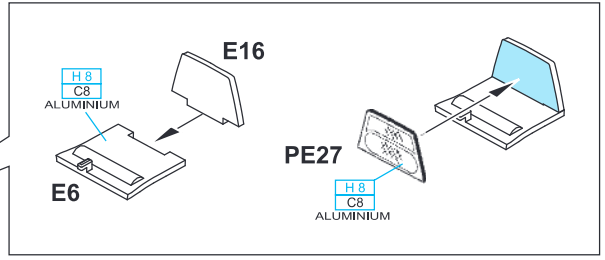
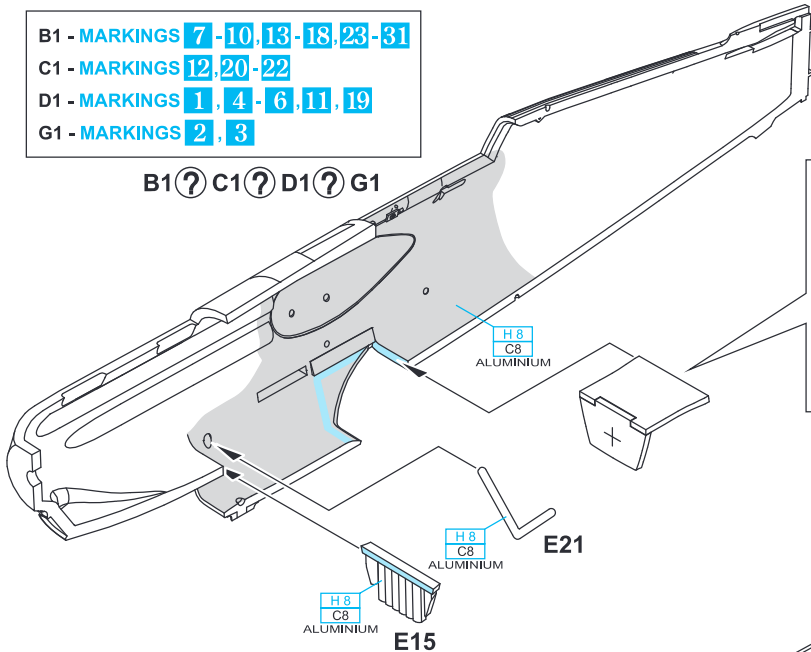

E18 - MARKINGS 1, 4-31 ONLY

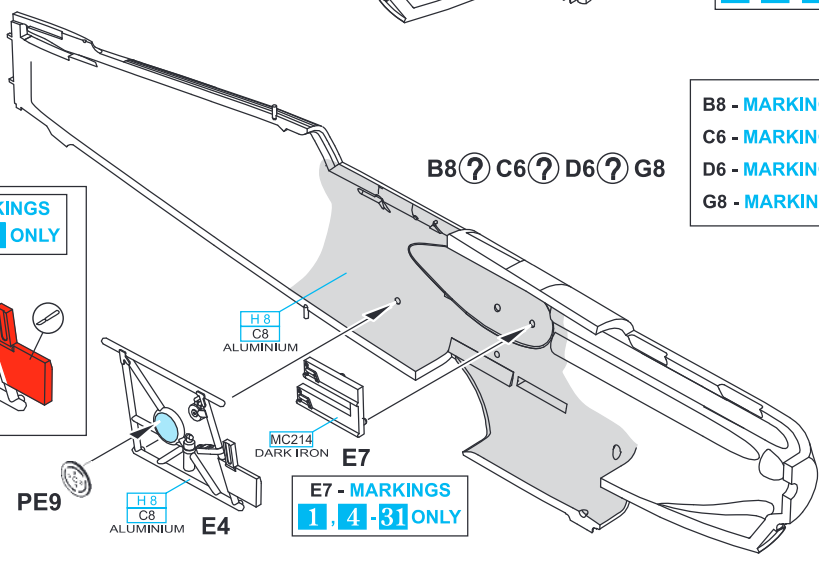

- B8 - MARKINGS 7-10, 13-18, 23-31
- C6 - MARKINGS 12, 20-22
- D6 - MARKINGS 1, 4-6, 11, 19
- G8 - MARKINGS 2, 3

B8 ? C6 ? D6 ? G8



E7 - MARKINGS 1, 4-31 ONLY

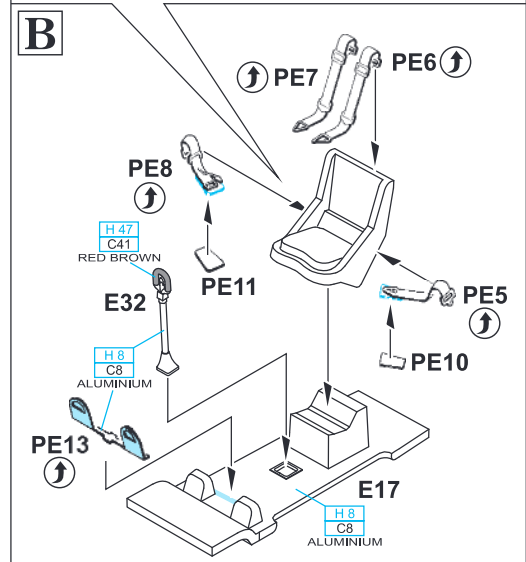
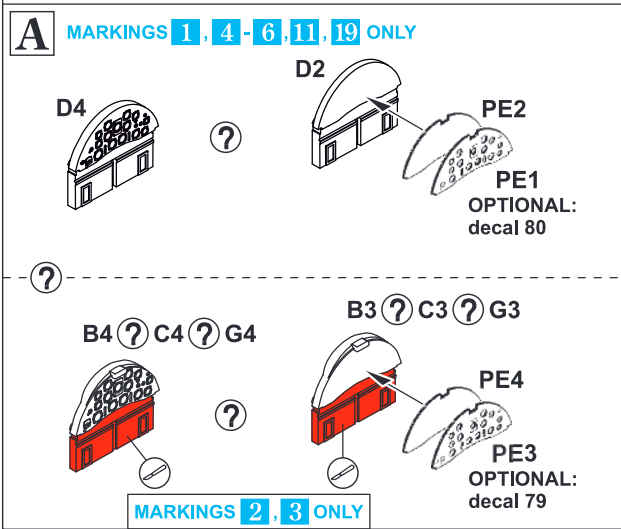
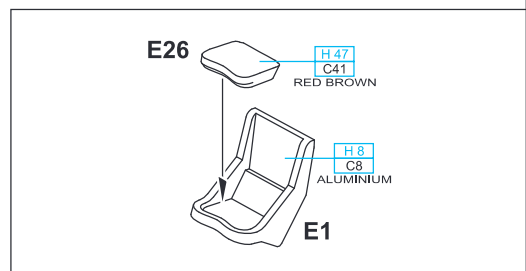

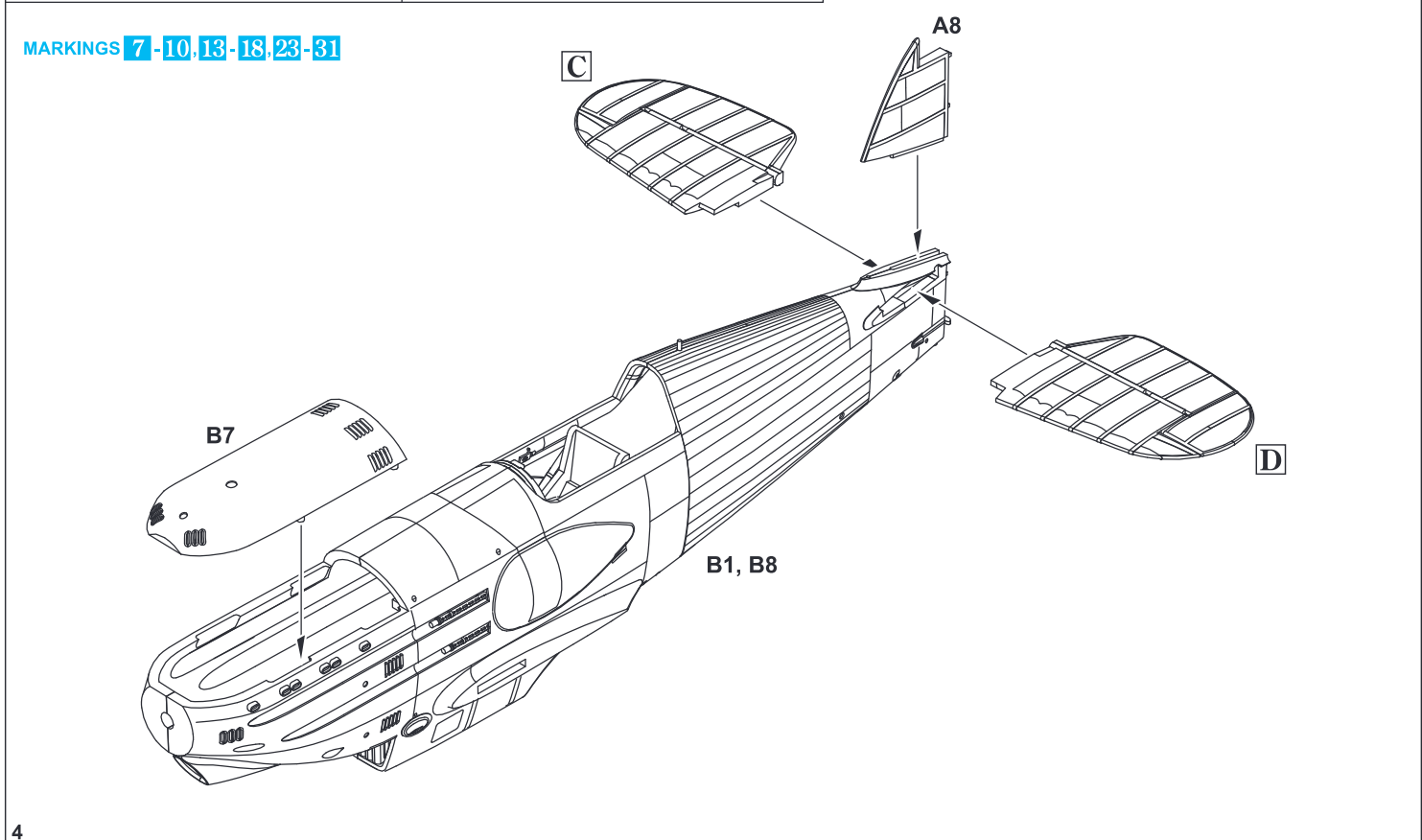
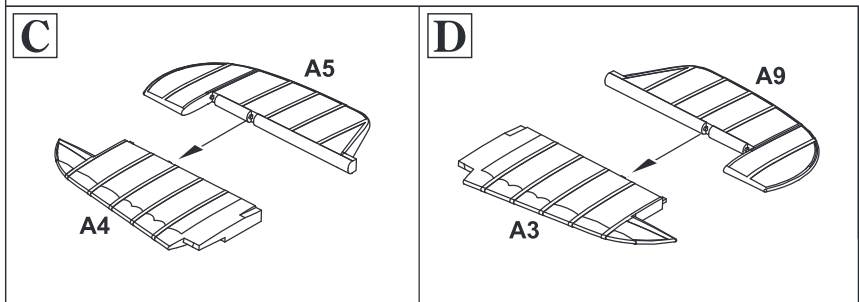
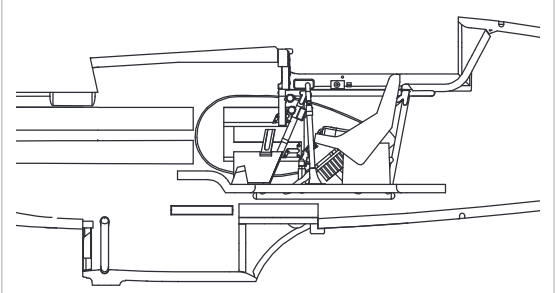
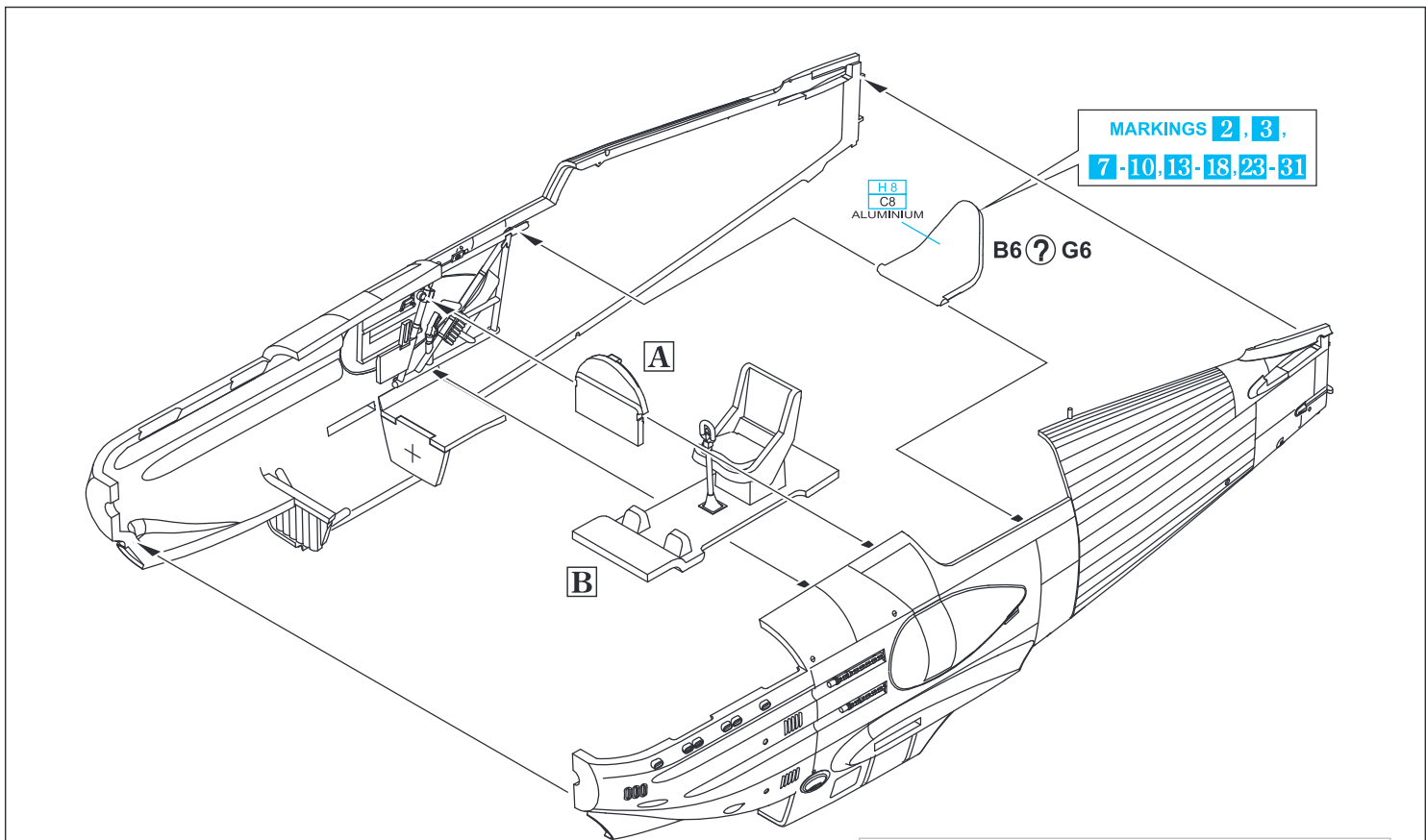

MARKINGS 1, 4, 6, 11, 19

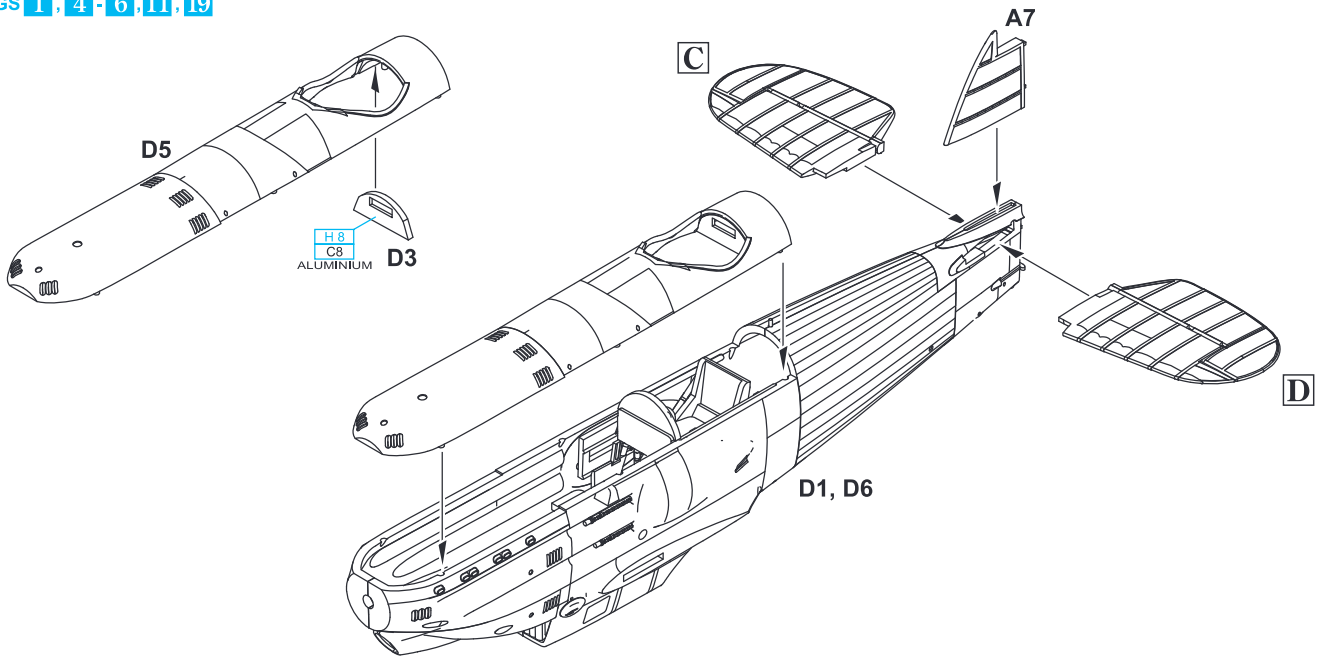

MARKINGS 12, 20-22

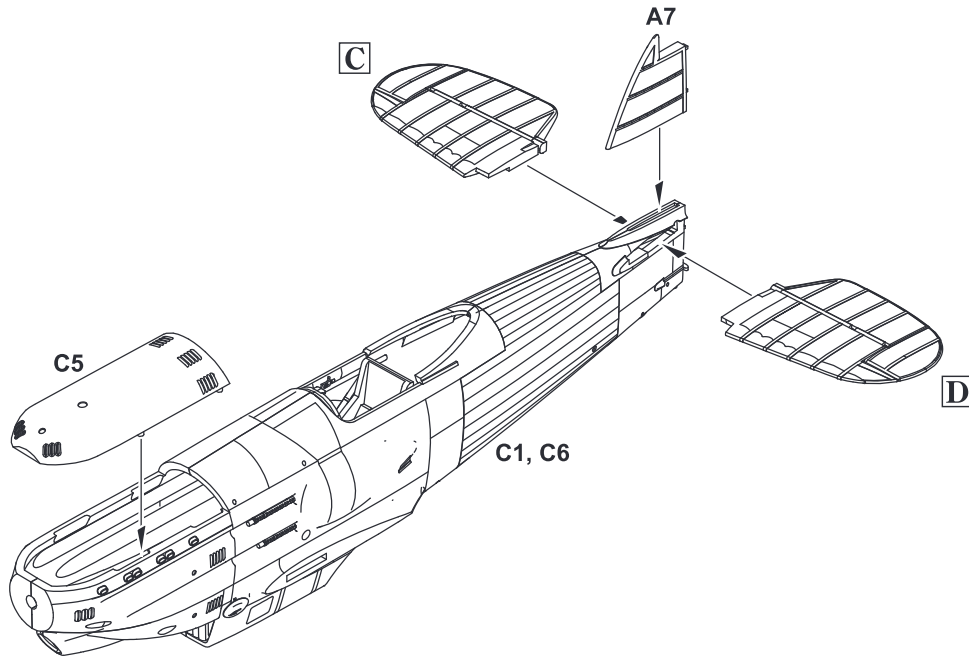

MARKINGS 2, 3

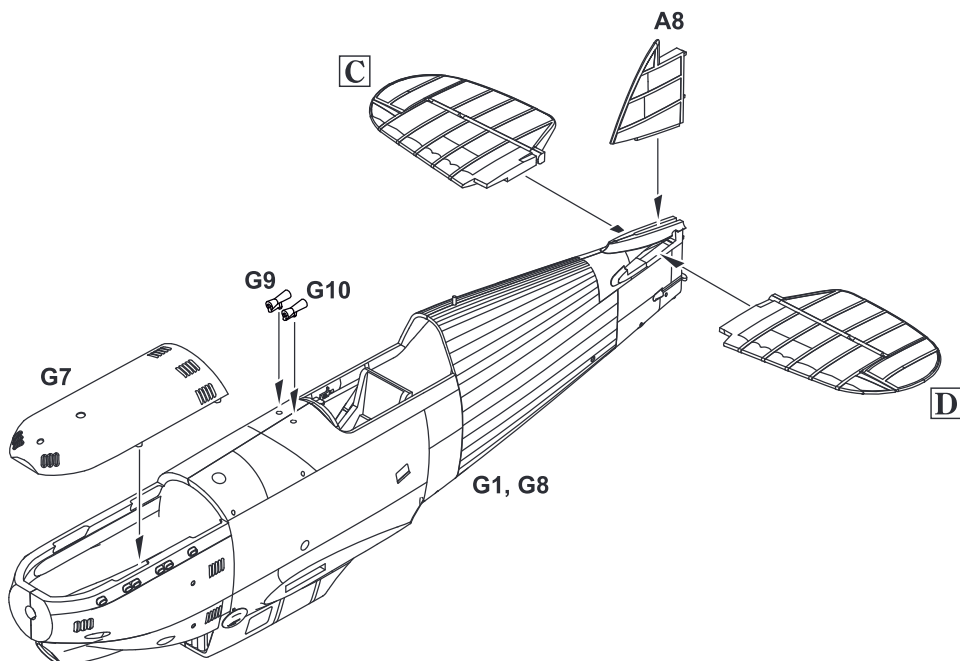

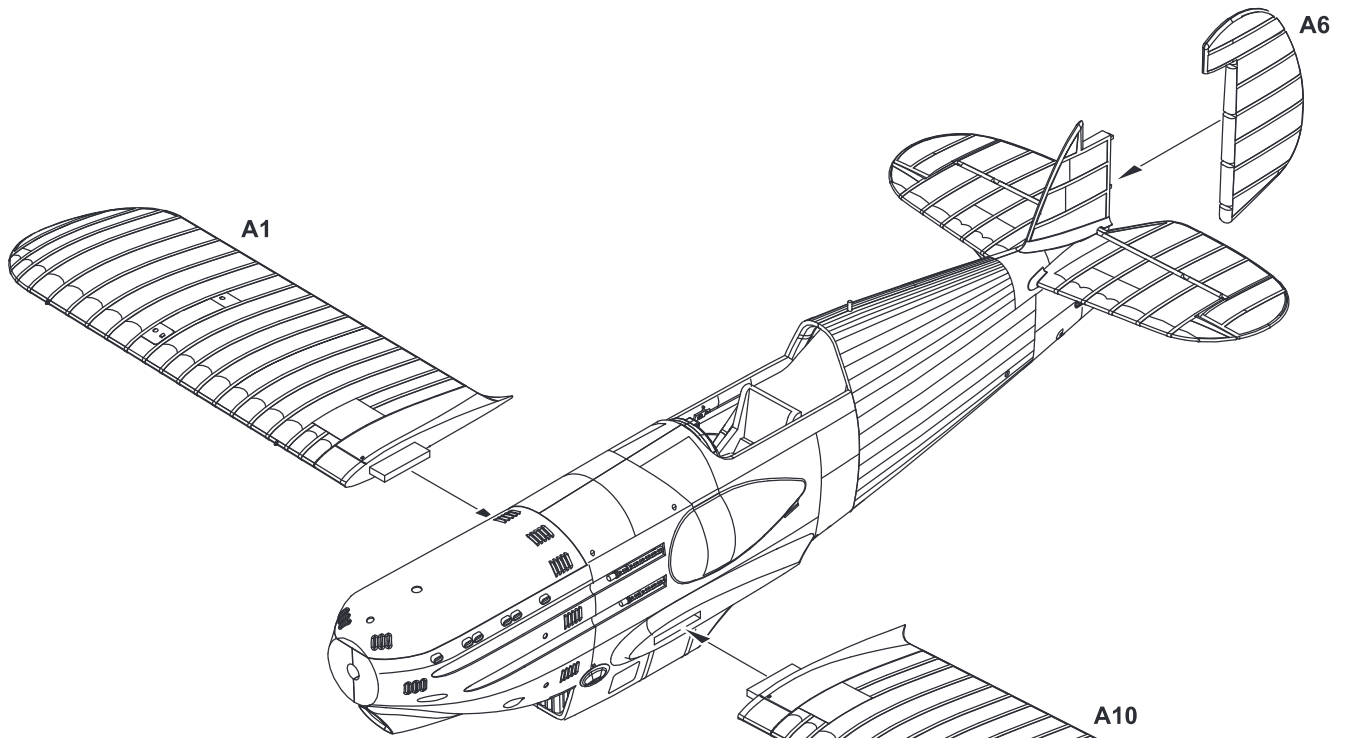

MARKING 15 ONLY

∅ - 0,5 mm
1 - 3 mm
plastic

DRILL THE HOLES FOR WIRES
AND STRETCHERS (see page 10)

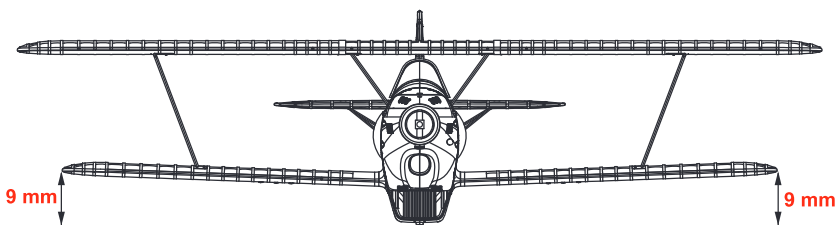
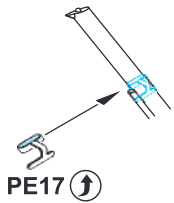
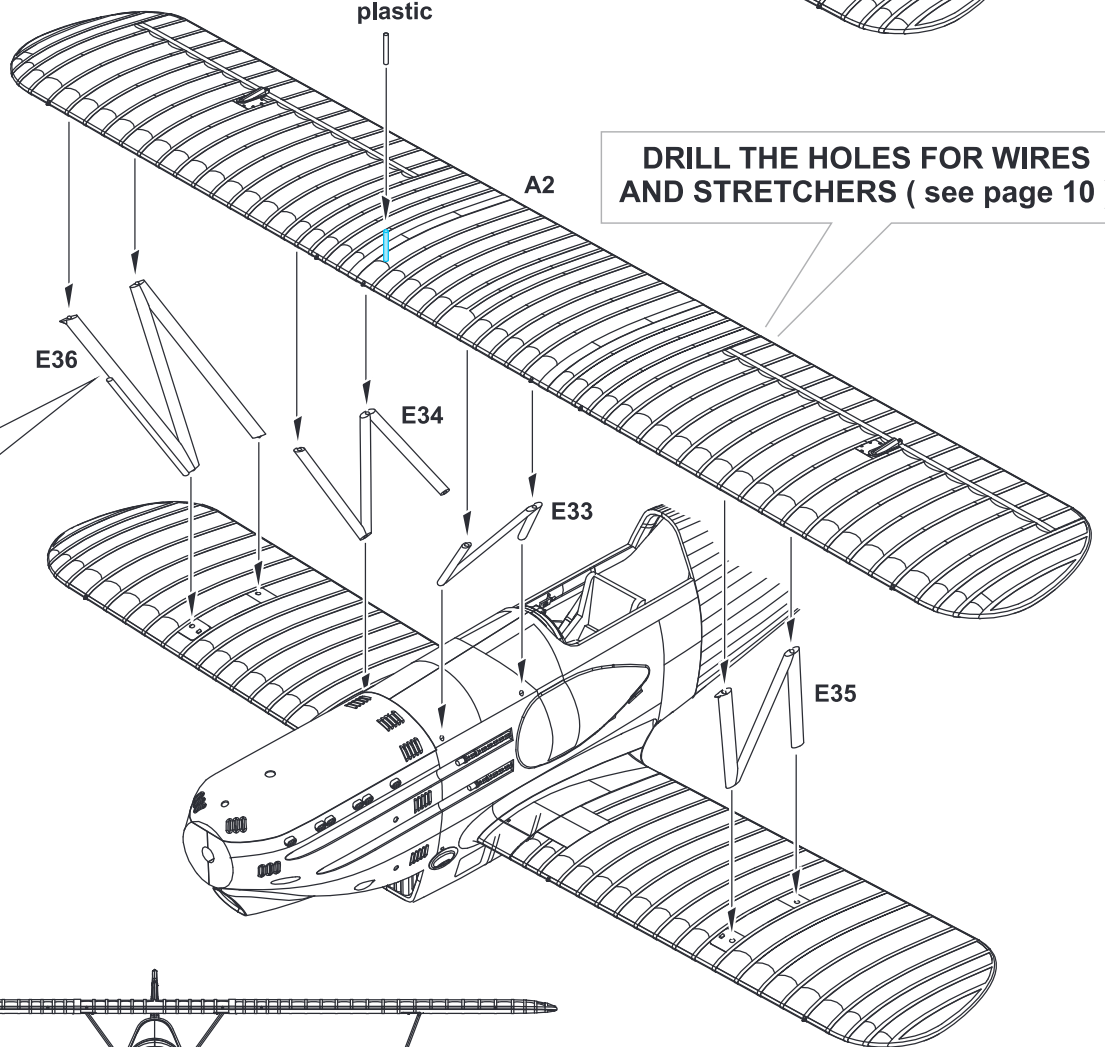

E12 - MARKINGS
1, 4, 6, 11, 12,
17-19, 25
ONLY

H 77
C137
TIRE BLACK

H 37
C43
WOOD BROWN

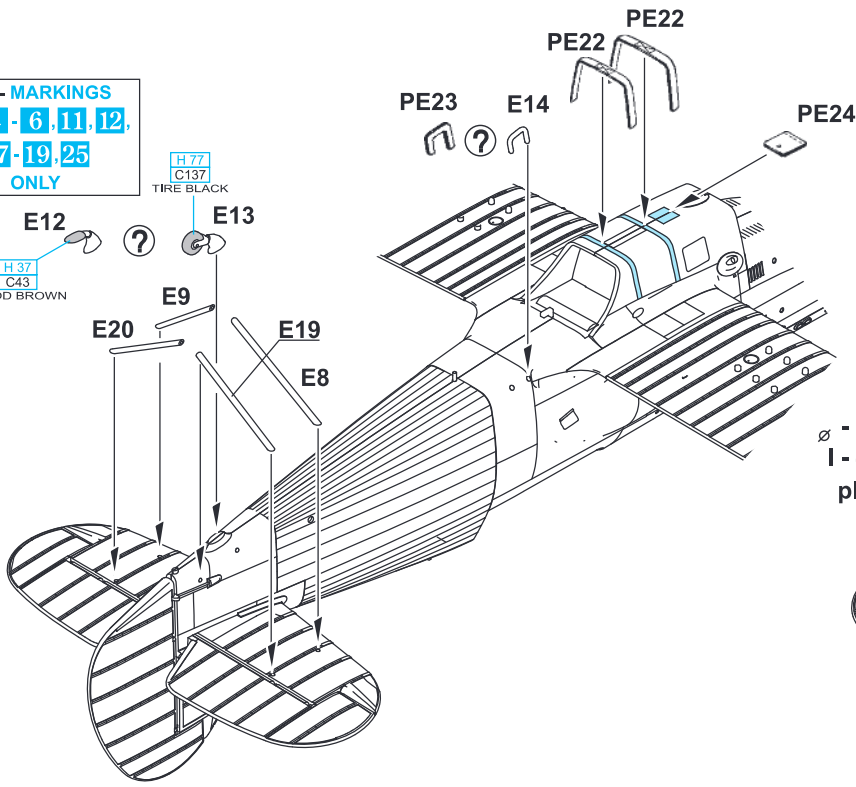

ø - 0,3 mm
 l - 4,7 mm
 plastic

MARKING 30 ONLY

plastic
 ø - 0,3 mm
 l - 4,7 mm

E MARKINGS **1, 4, 6, 11, 19-21** MARKINGS **2, 3, 7, 10, 12, 18, 22-31**

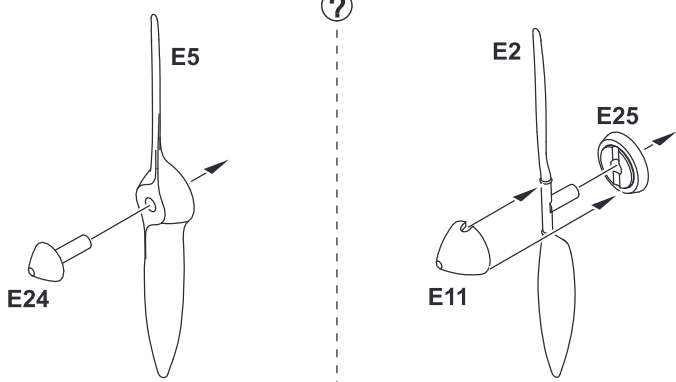

F 6 pcs.

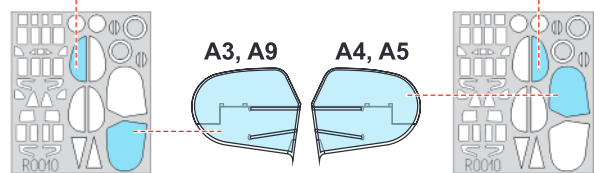
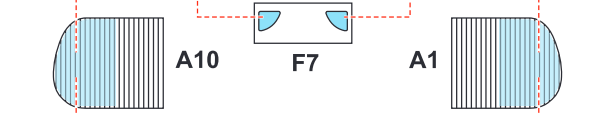
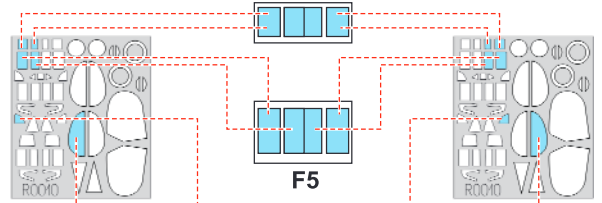
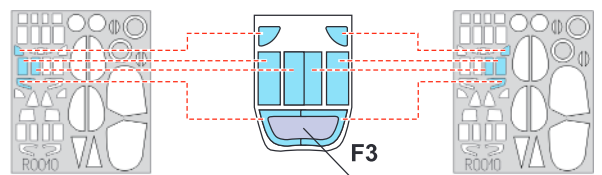
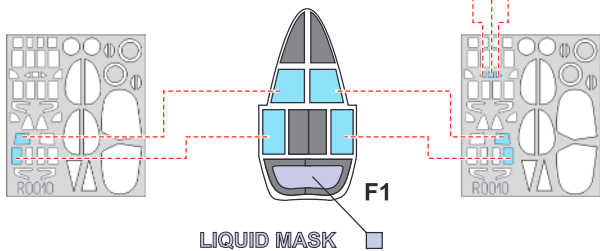
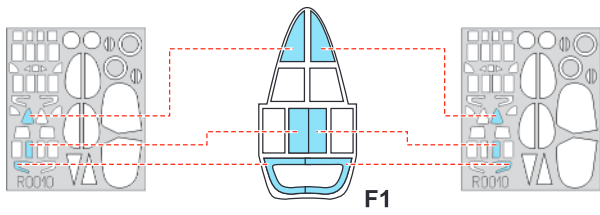
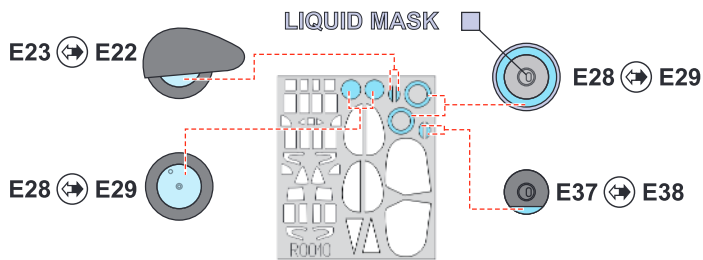
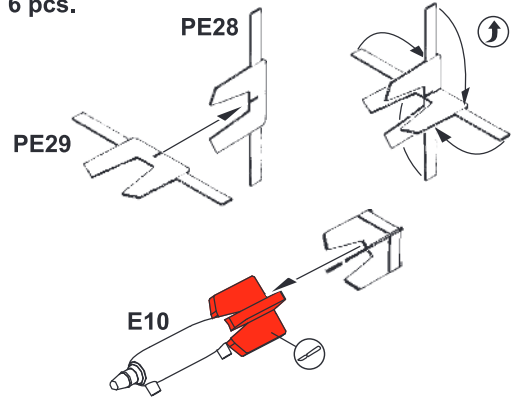

MARKINGS 2 - 5, 8 - 10, 27 ONLY

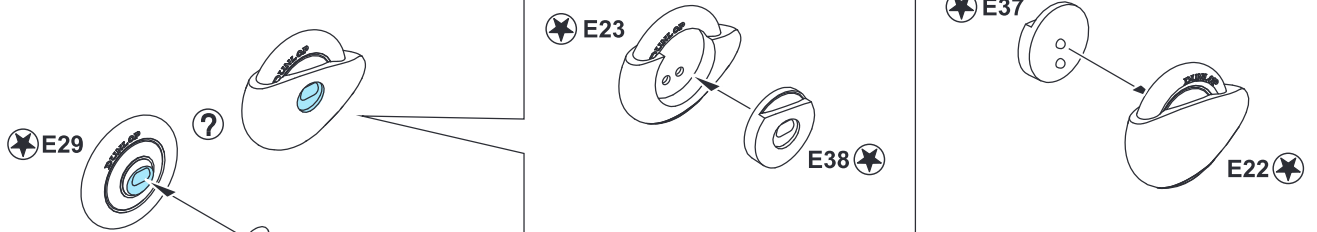

MARKINGS 7, 8, 16, 27 ONLY

H 12 C33 ? H 64 C17
FLAT BLACK BLACK GREEN

3 pcs. E10

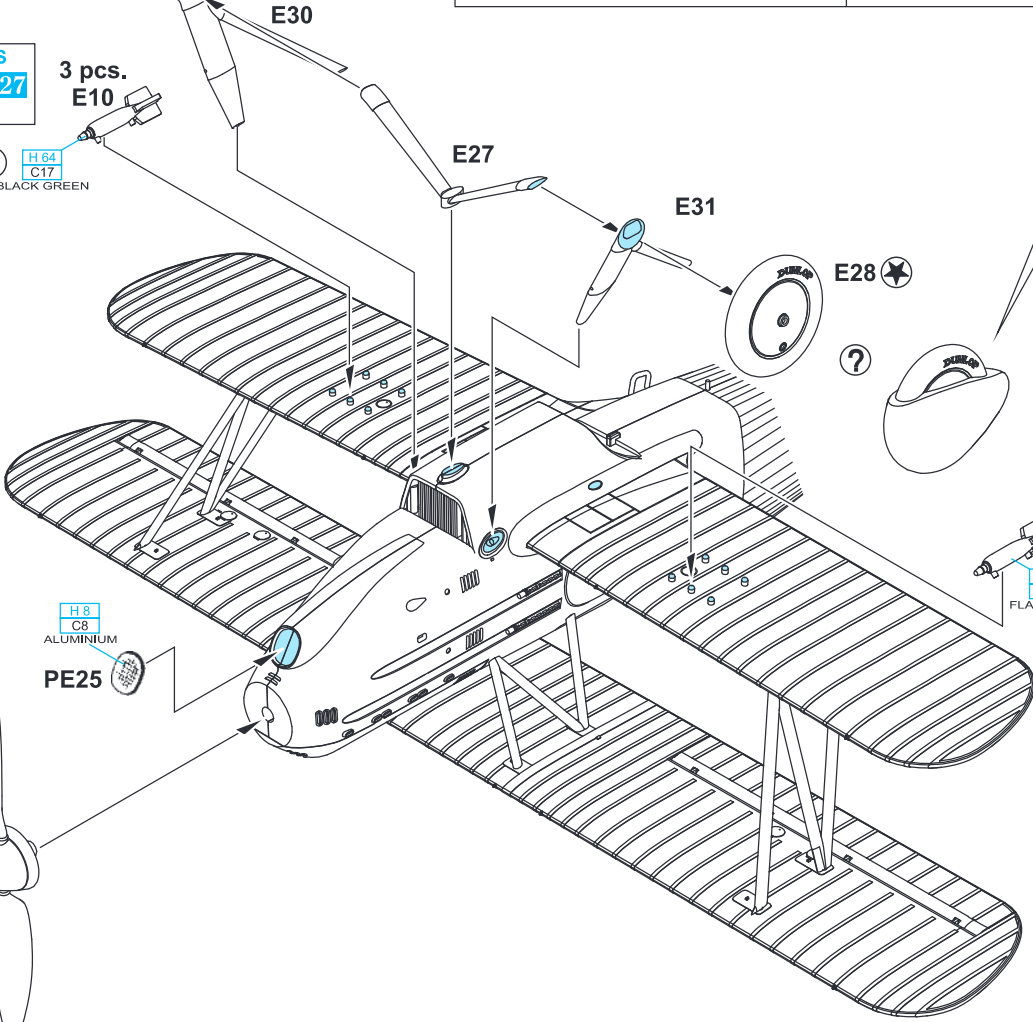

MARKINGS 7, 8, 16, 27 ONLY

3 pcs. E10
H 12 C33 ? H 64 C17
FLAT BLACK BLACK GREEN

H 8 C8 ALUMINIUM

PE25

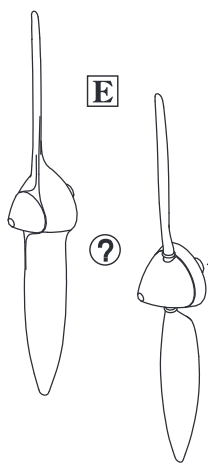

MARKING 26 ONLY

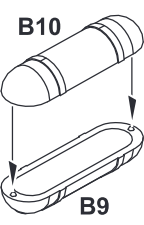

H 51 C11 LIGHT GRAY

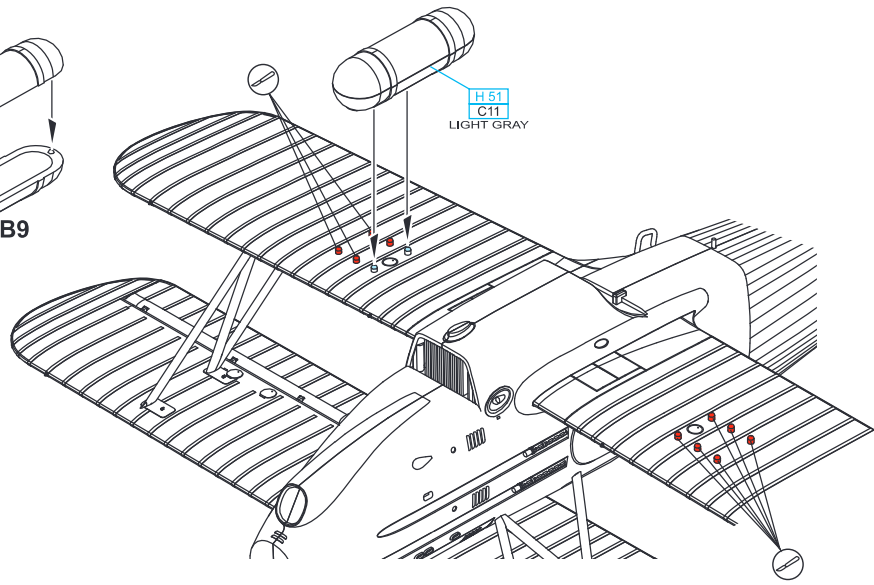

PE26
H 12 C33 FLAT BLACK

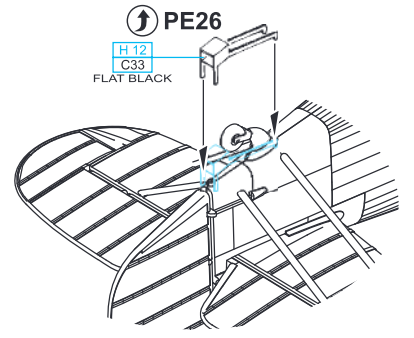

MARKINGS 2, 3, 7-10,
13-18, 23-31

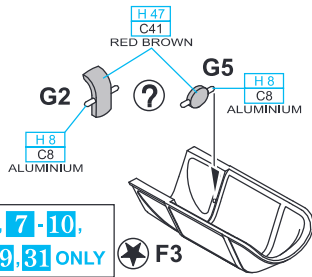

F3 - MARKINGS 2, 3, 7-10,
13-15, 17, 18, 25, 27, 29, 31 ONLY

★ F3

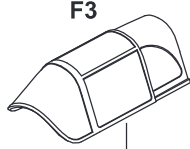

F3

PE12 - MARKINGS
7-10, 13-18, 23-31
ONLY

↑ PE12

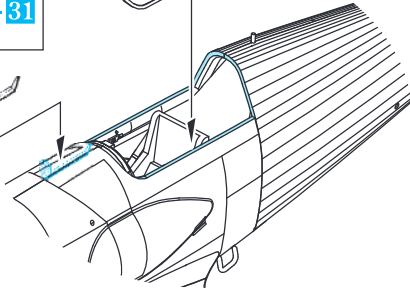

F5 - MARKINGS 2, 3, 7-10,
13-15, 17, 18, 23-31 ONLY

★ F5

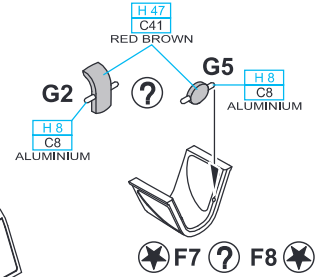

★ F7 ? F8 ★

F8 - MARKINGS
23, 24, 26, 28, 30
ONLY

★ F4



PE12 - MARKINGS
7-10, 13-18, 23-31
ONLY

↑ PE12

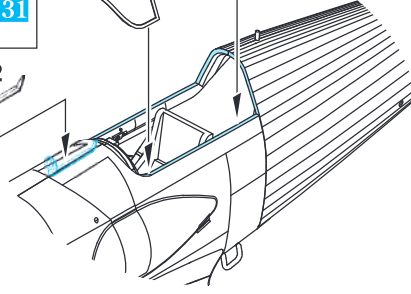

MARKINGS 12, 20-22

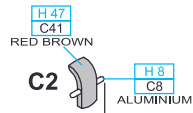

★ F1

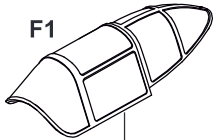

F1

↑ PE12

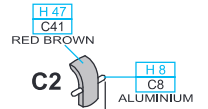
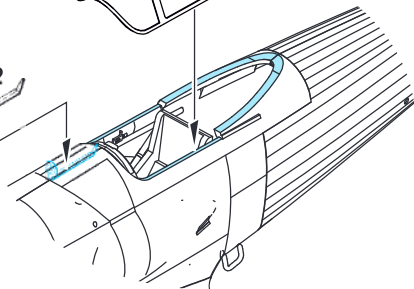

★ F6

★ F5

★ F4

↑ PE12

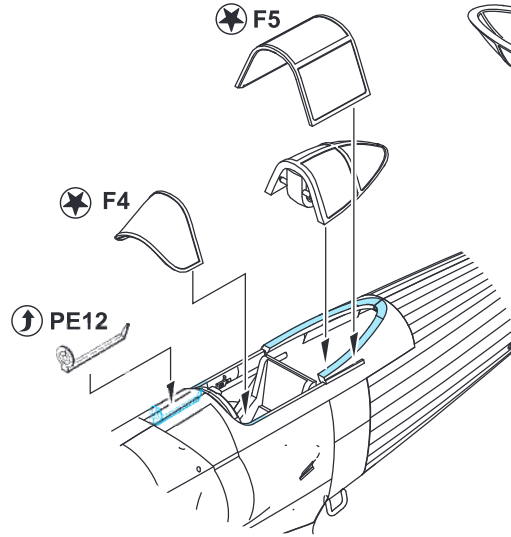

MARKINGS 1, 4-6, 11, 19

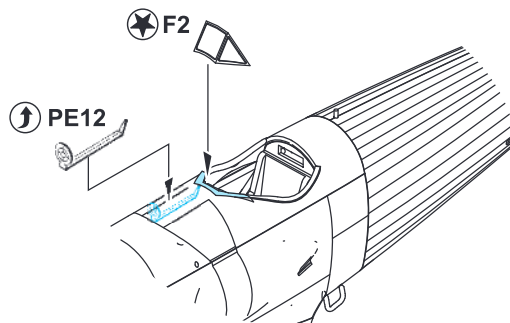

★ F2

↑ PE12

WINGS BRACING ASSEMBLY

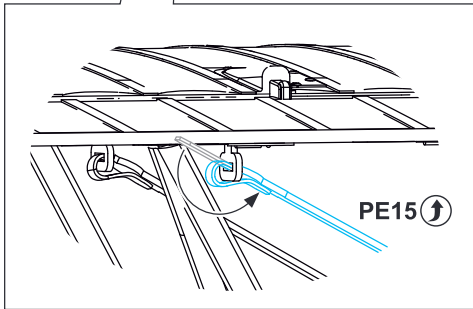
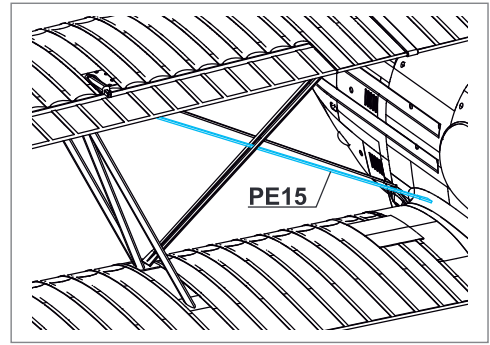
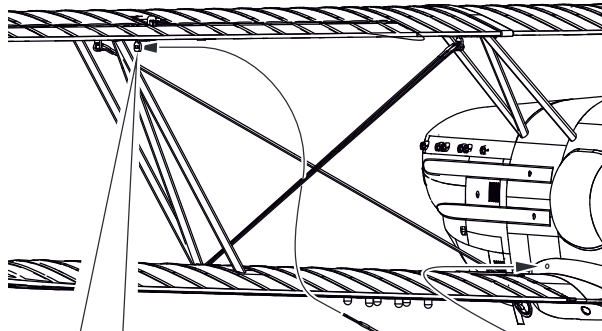

↔ ↑ PE15

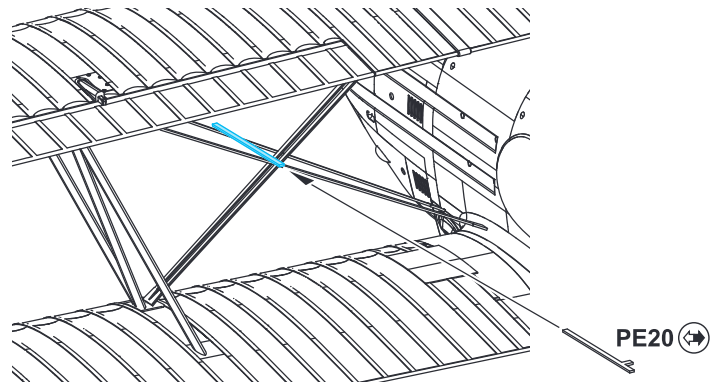

PE20 ↔

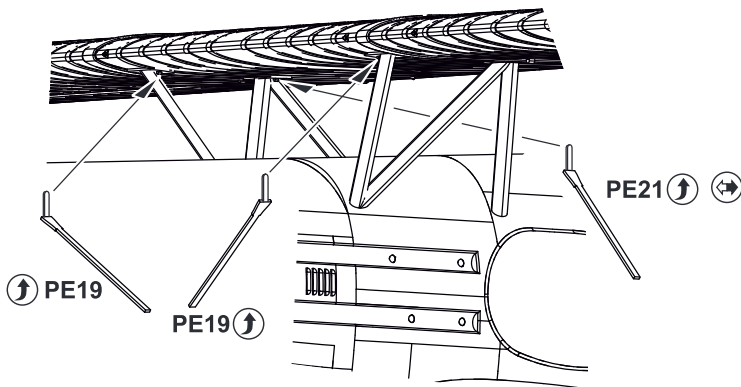

↑ PE19

PE19 ↑

PE21 ↑ ↔

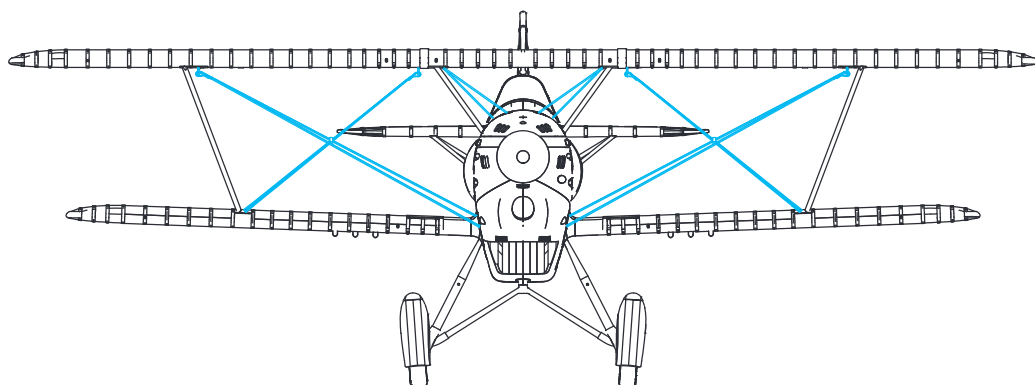
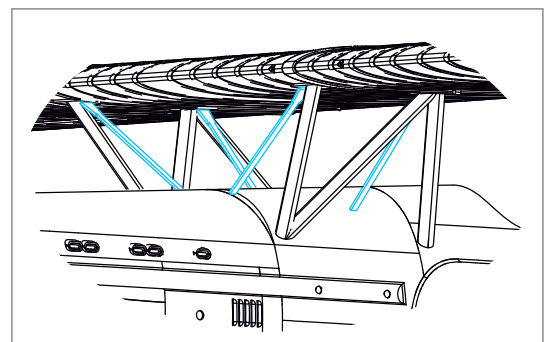

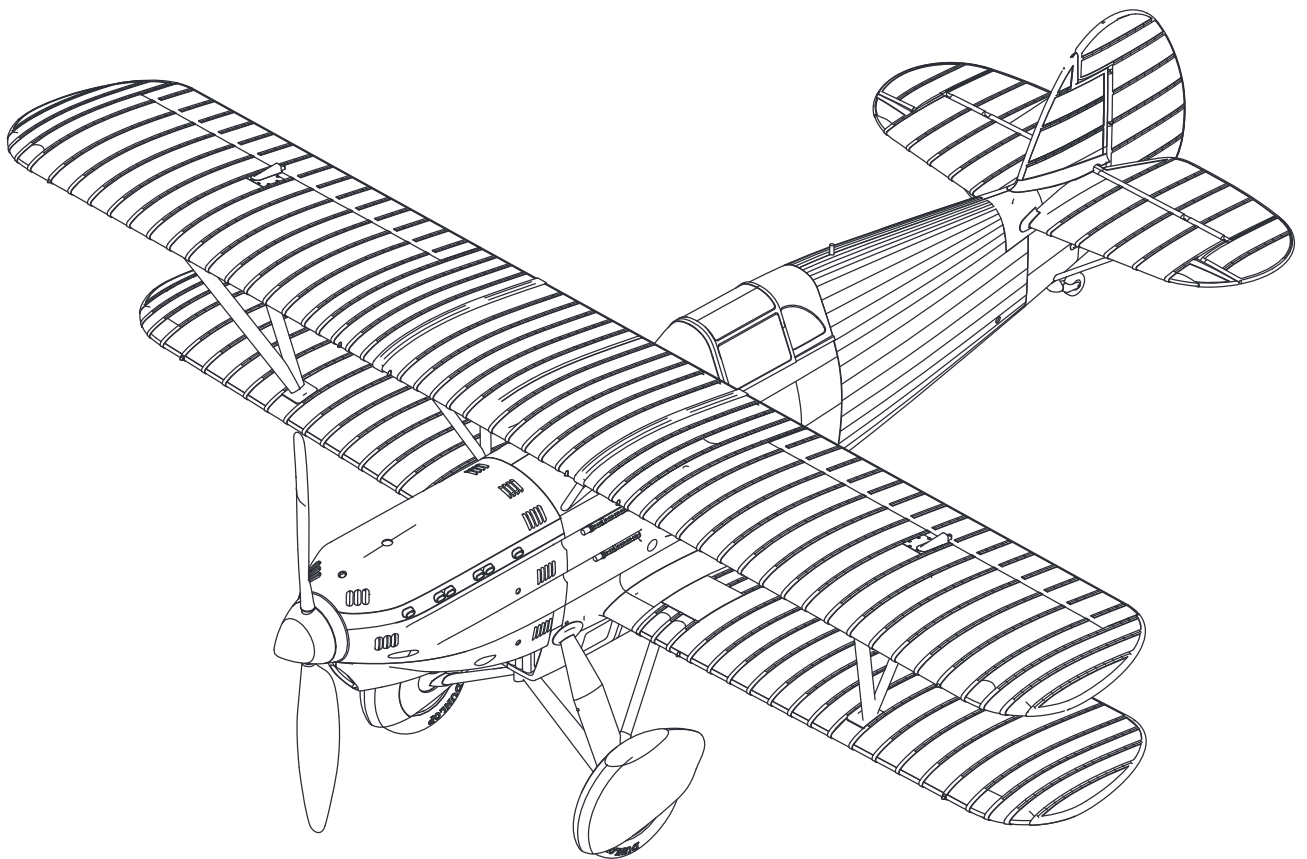
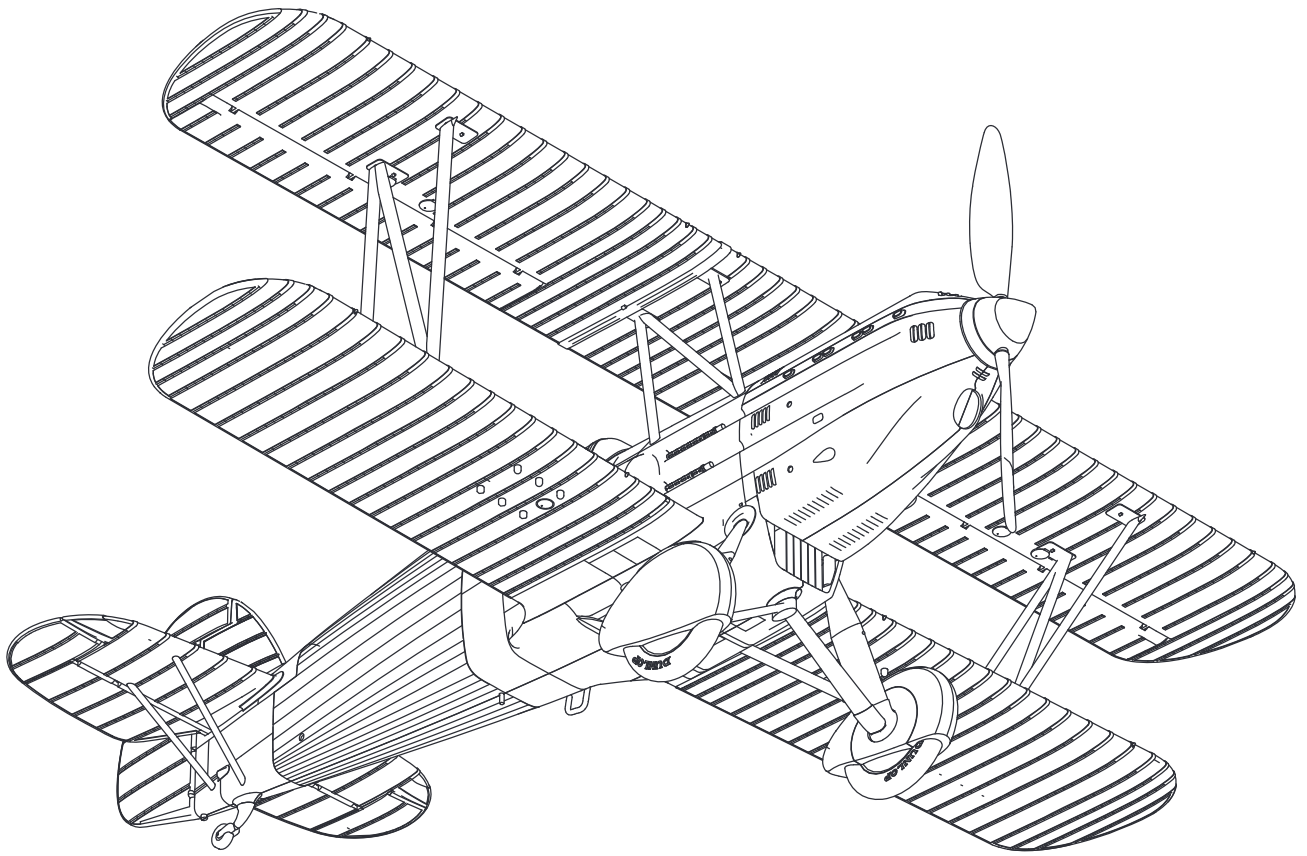

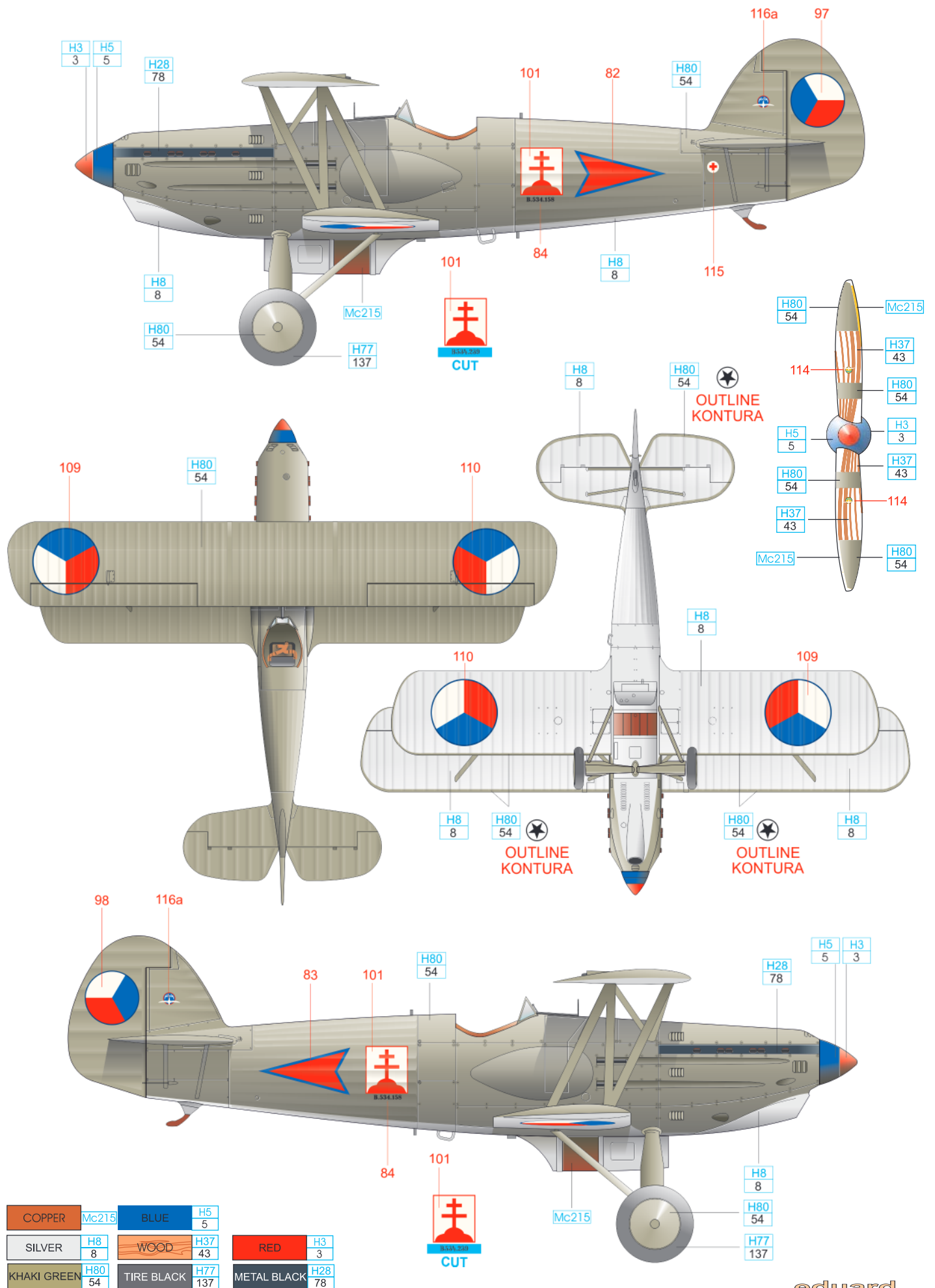

COPPER	Mc215	BLUE	H5 5
SILVER	H8 8	WOOD	H37 43
KHAKI GREEN	H80 54	TIRE BLACK	H77 137
		METAL BLACK	H28 78

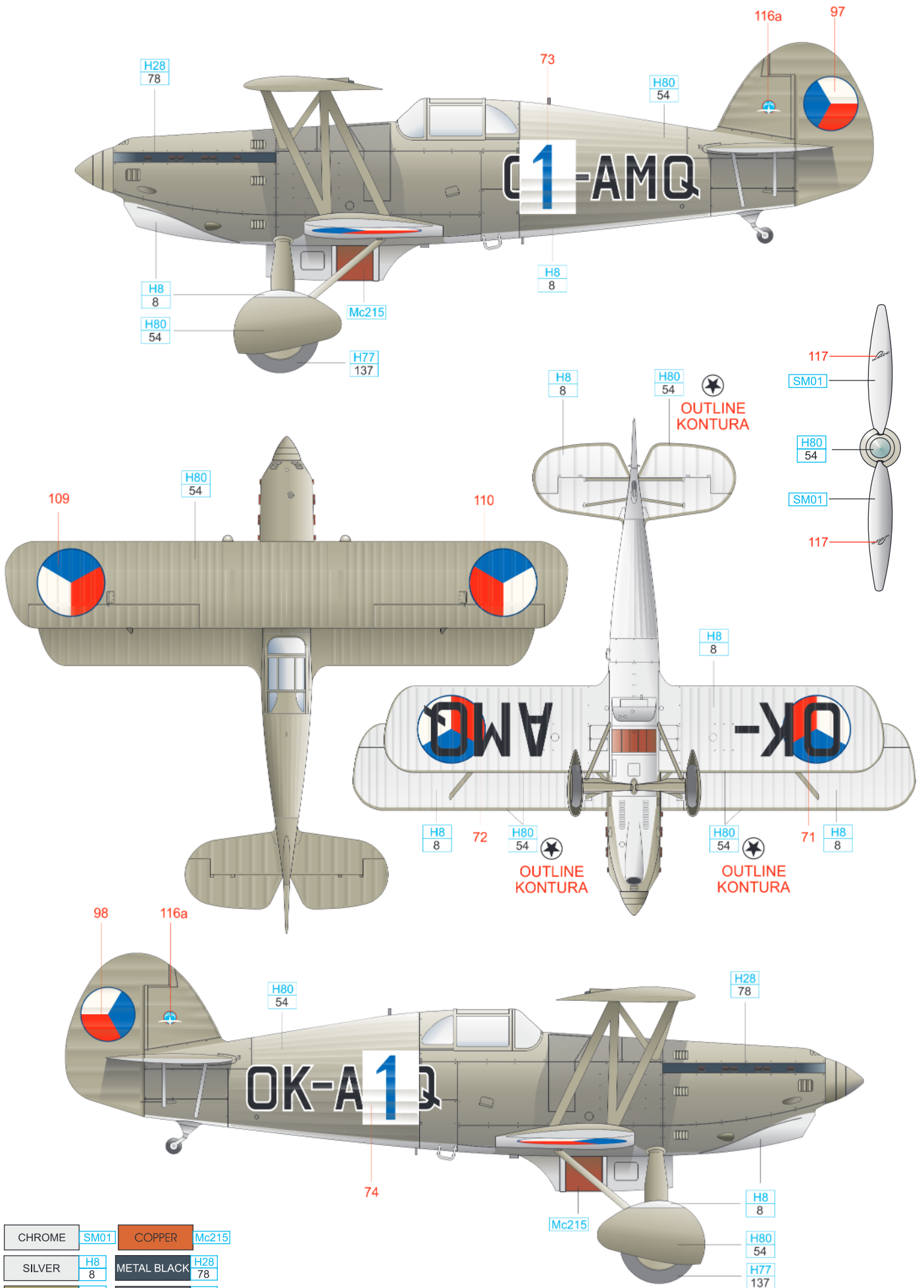

CHROME	SM01	COPPER	Mc215
SILVER	H8 8	METAL BLACK	H28 78
KHAKI GREEN	H80 54	TIRE BLACK	H77 137

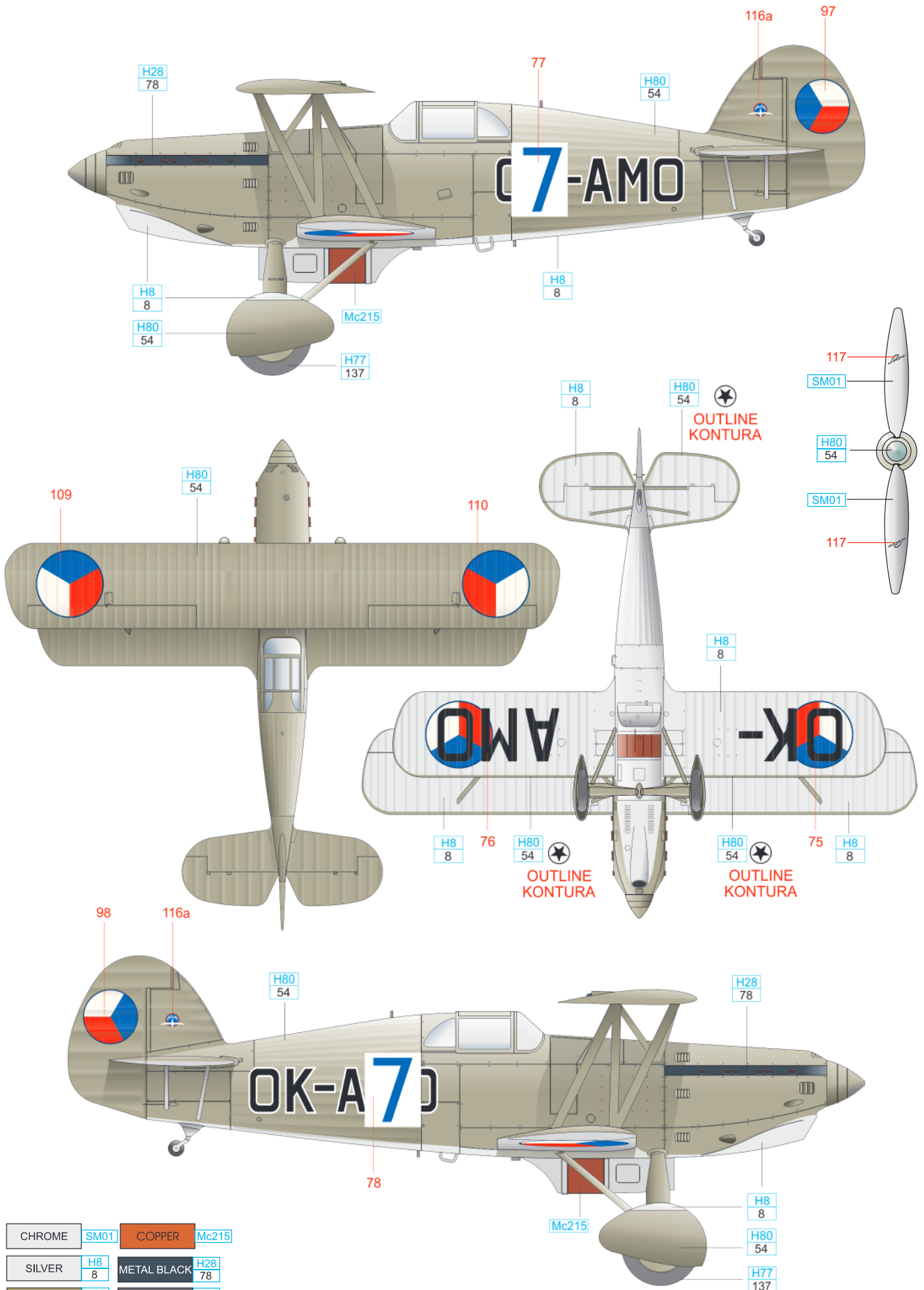

CHROME	SM01	COPPER	Mc215
SILVER	H8 8	METAL BLACK	H28 78
KHAKI GREEN	H80 54	TIRE BLACK	H77 137

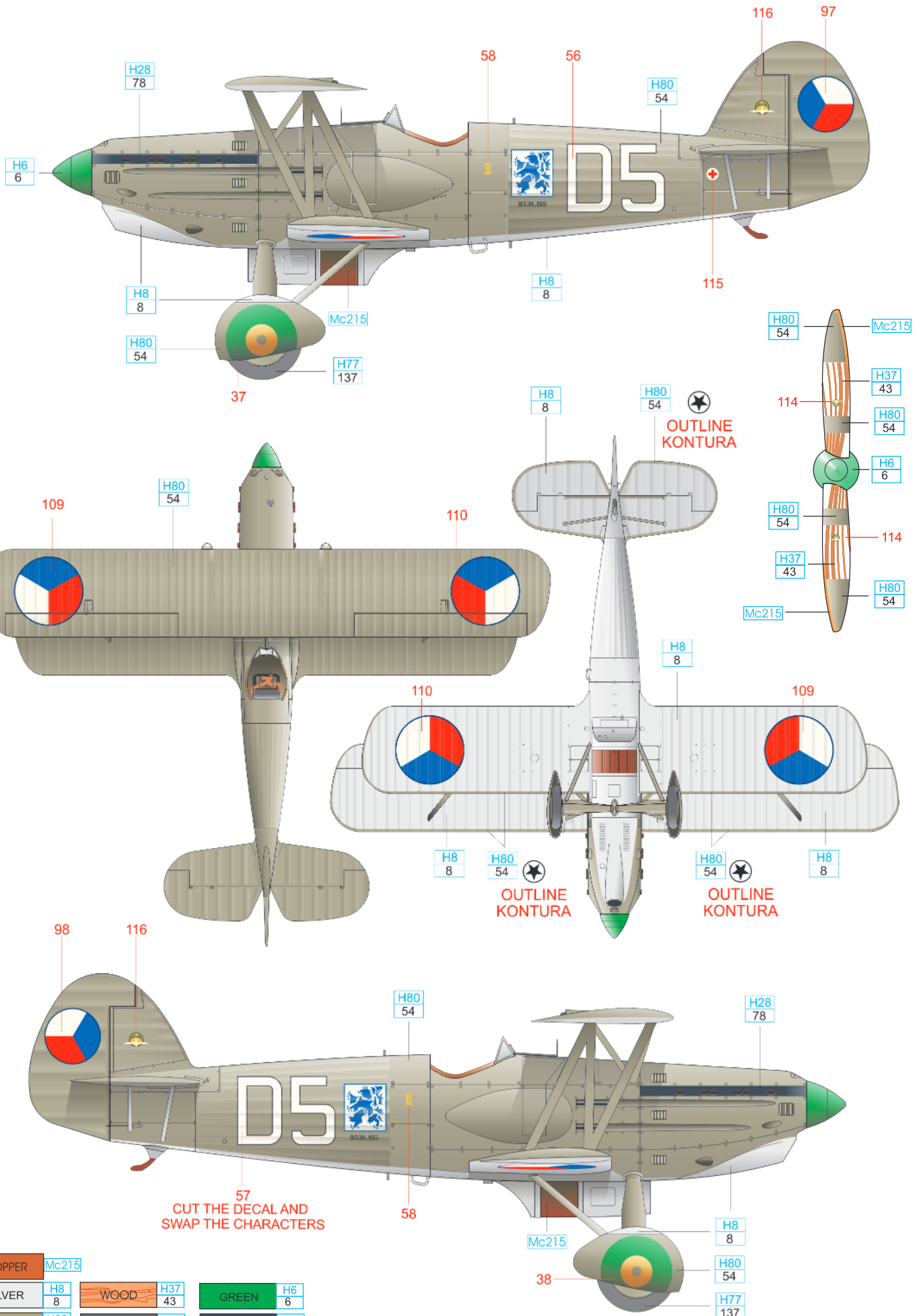

COPPER	Mc215	WOOD	H37 43	GREEN	H6 6
SILVER	H8 8	TIRE BLACK	H77 137	METAL BLACK	H28 78
KHAKI GREEN	H80 54				

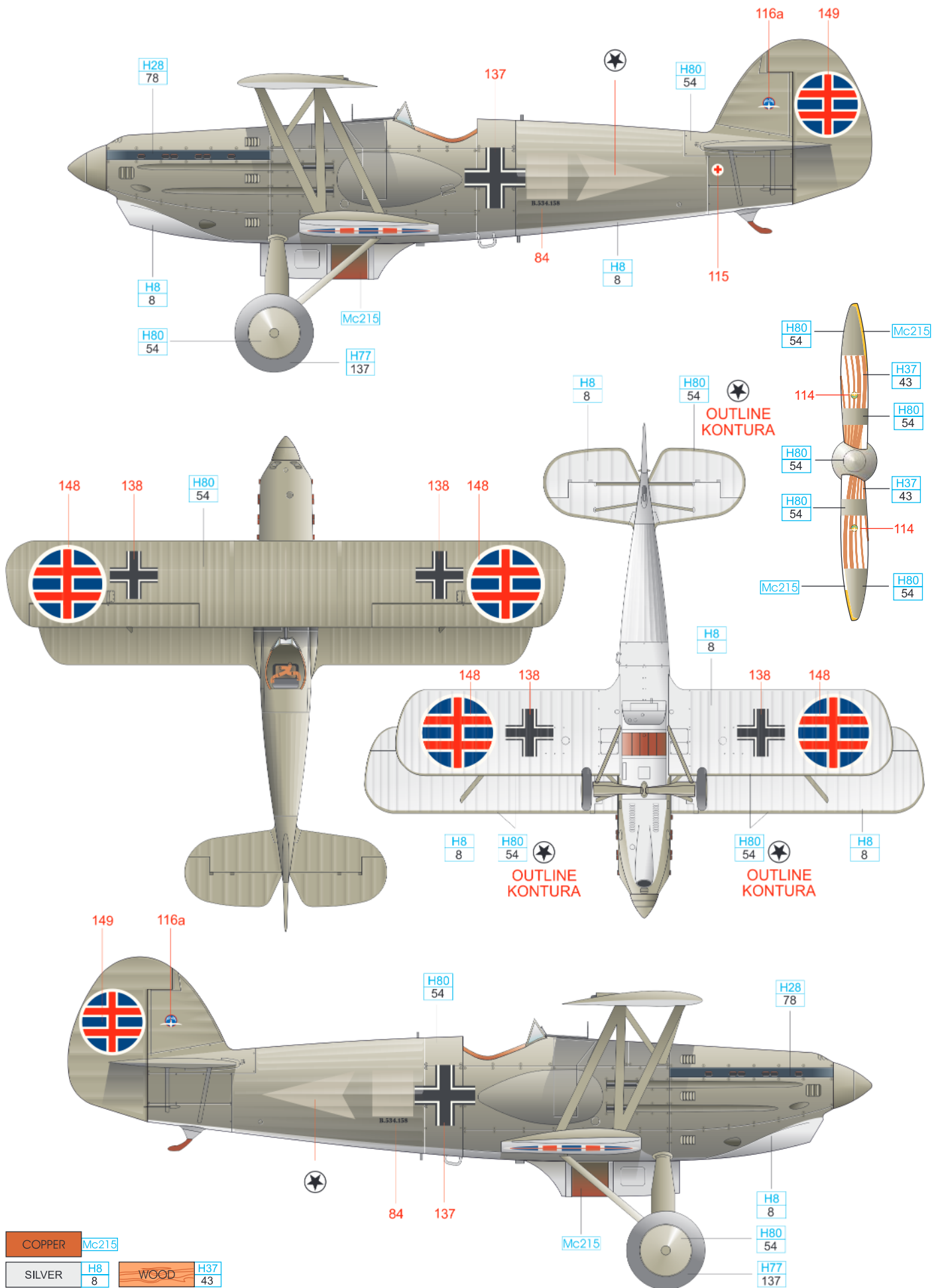

COPPER	Mc215	WOOD	H37	METAL BLACK	H28
SILVER	H8		43		78
	8	TIRE BLACK	H77		
KHAKI GREEN	H80		137		
	54				

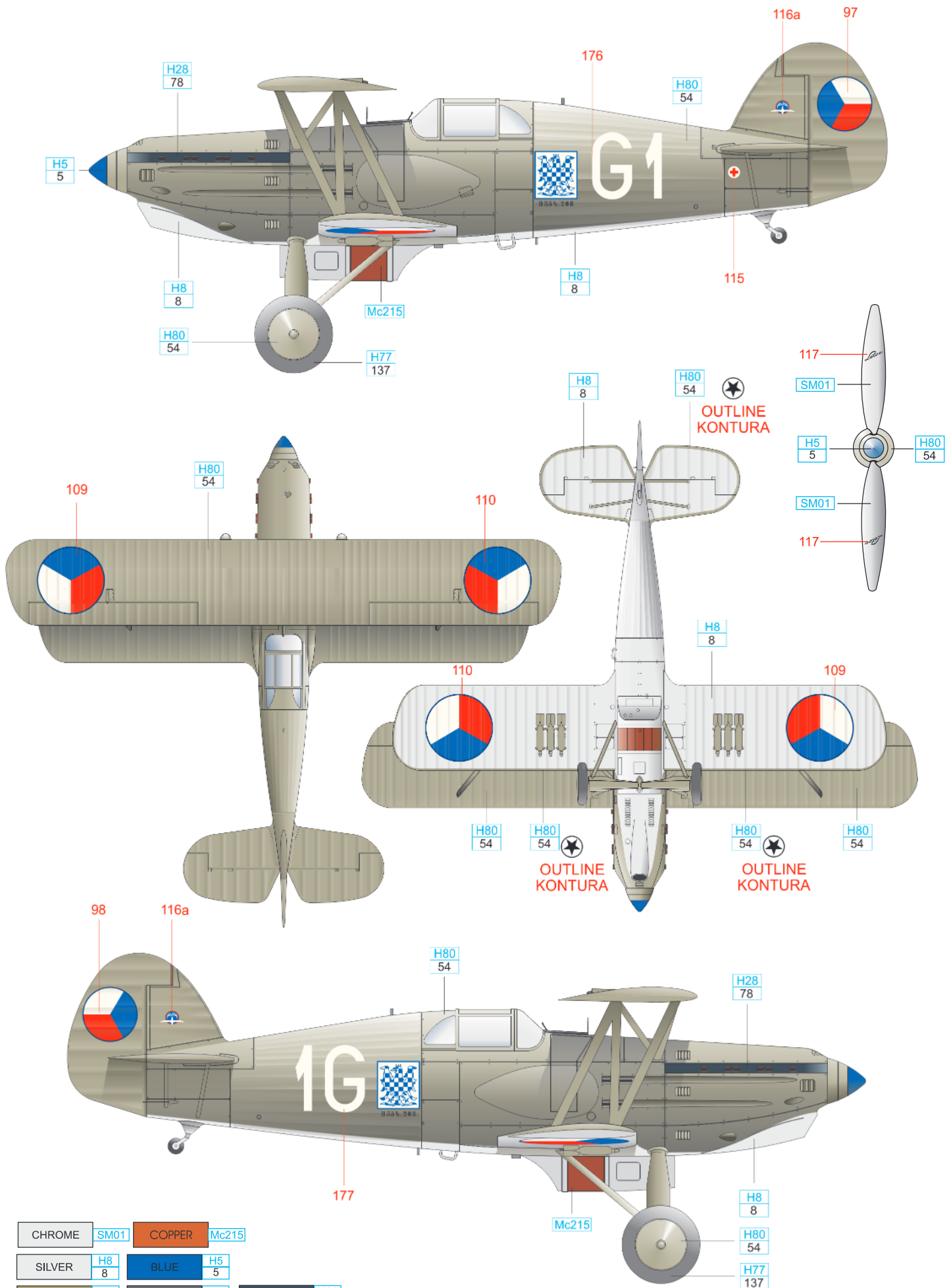

CHROME	SM01	COPPER	Mc215
SILVER	H8 8	BLUE	H5 5
KHAKI GREEN	H80 54	TIRE BLACK	H77 137
		METAL BLACK	H28 78

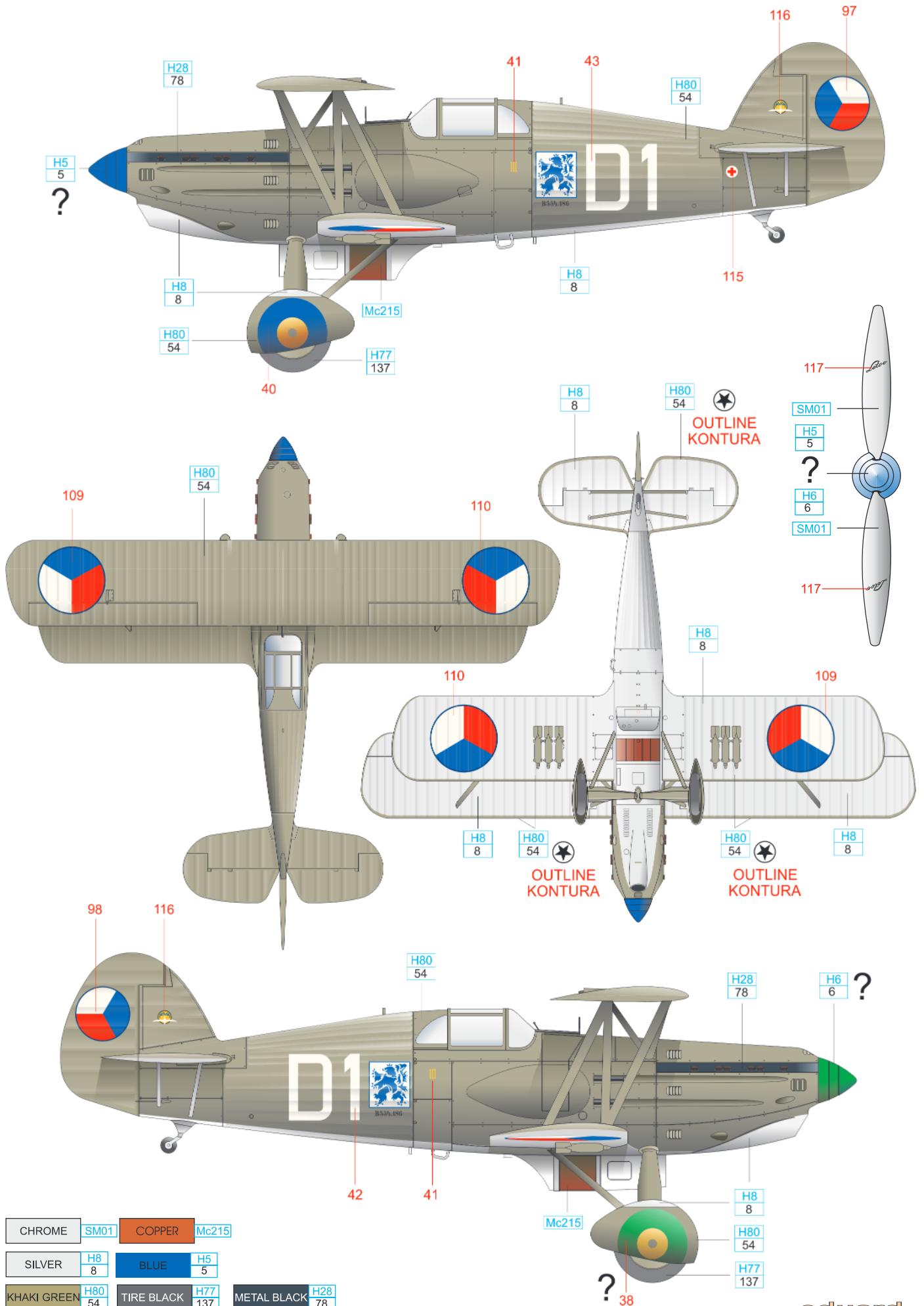

CHROME SM01 COPPER Mc215

SILVER H8 8 BLUE H5 5

KHAKI GREEN H80 54 TIRE BLACK H77 137 METAL BLACK H28 78

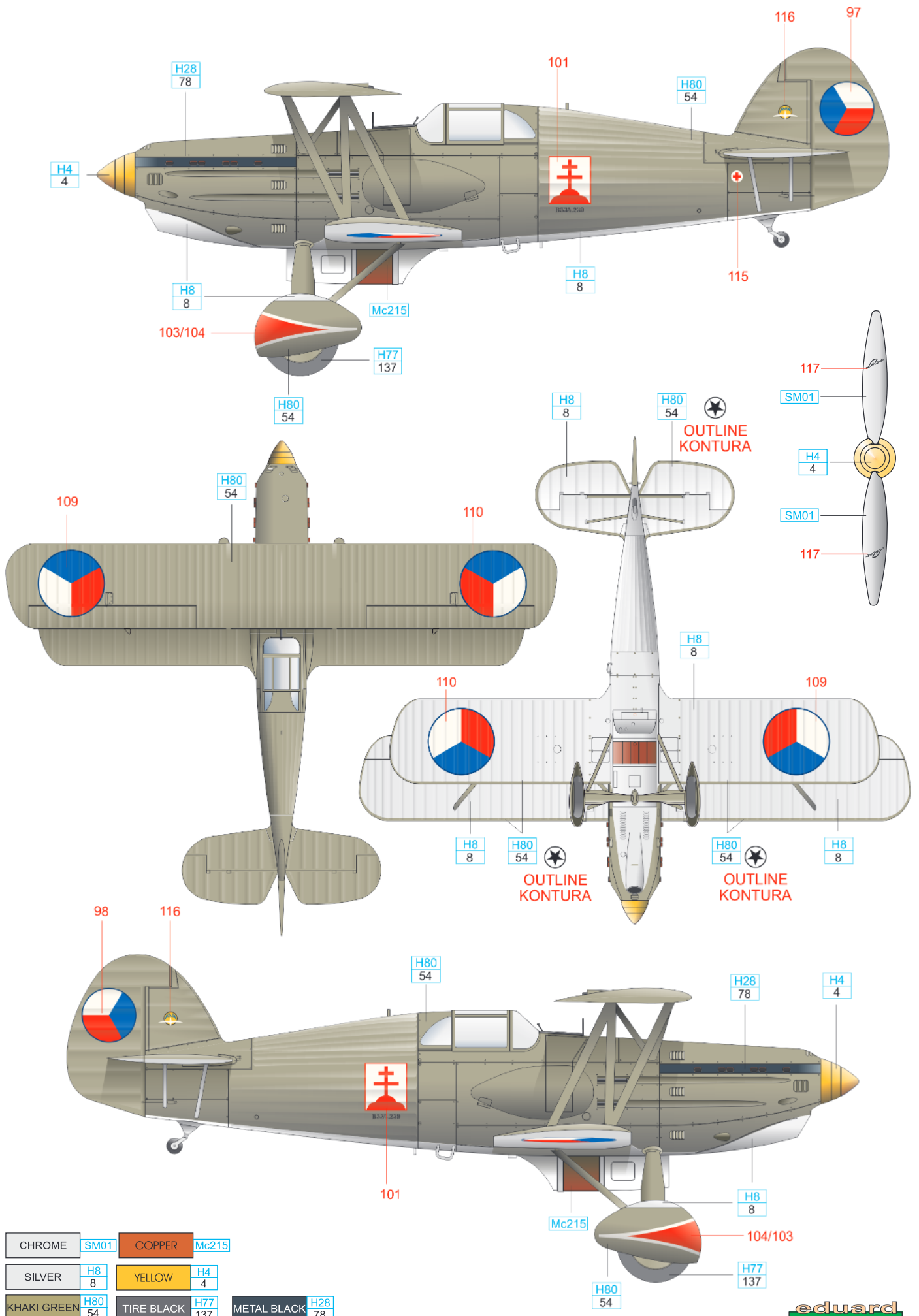

CHROME	SM01	COPPER	Mc215
SILVER	H8 8	YELLOW	H4 4
KHAKI GREEN	H80 54	TIRE BLACK	H77 137
		METAL BLACK	H28 78

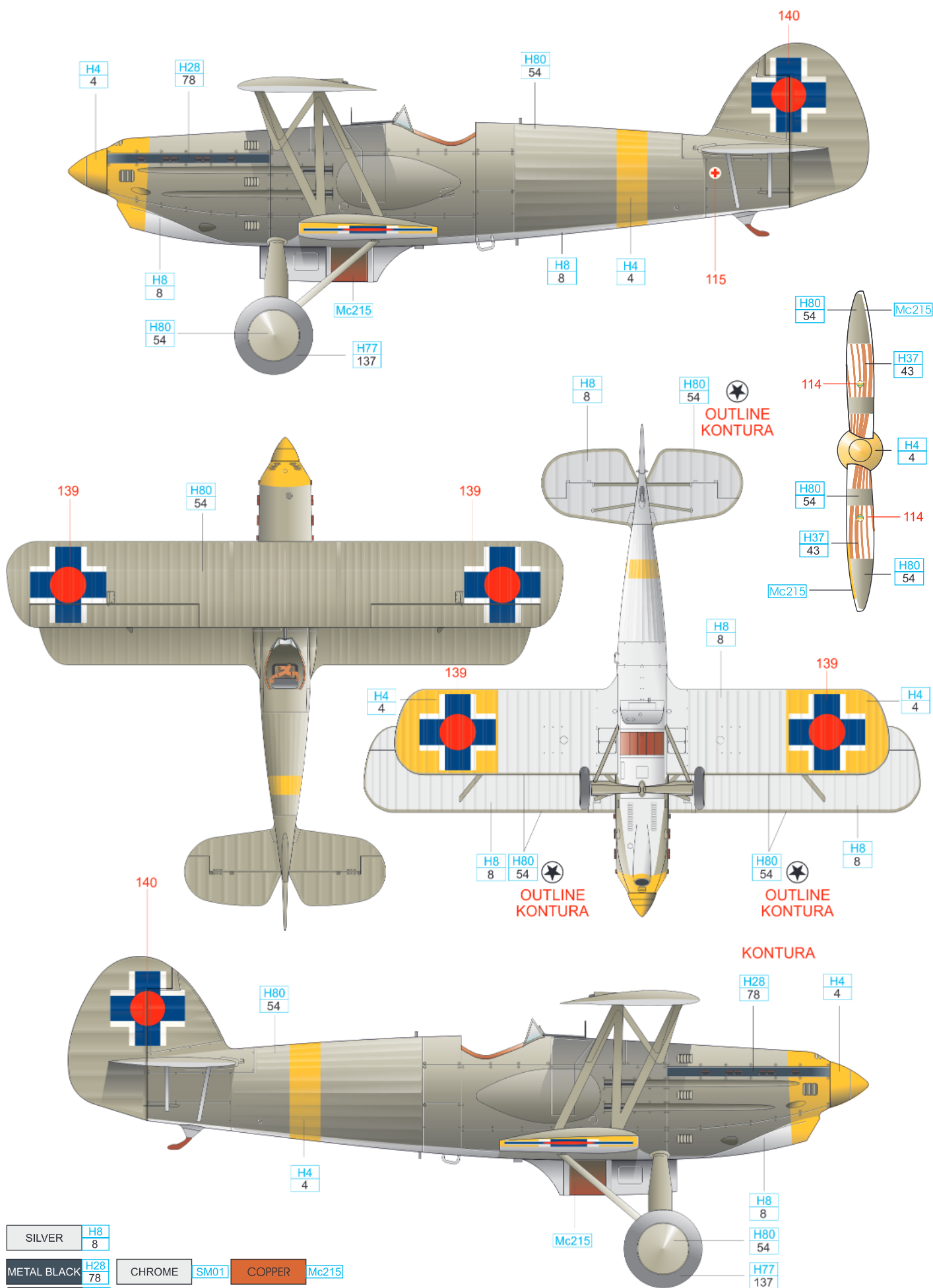

SILVER	H8 8	CHROME	SM01	COPPER	Mc215
METAL BLACK	H28 78	TIRE BLACK	H77 137	YELLOW	H4 4
KHAKI GREEN	H80 54				

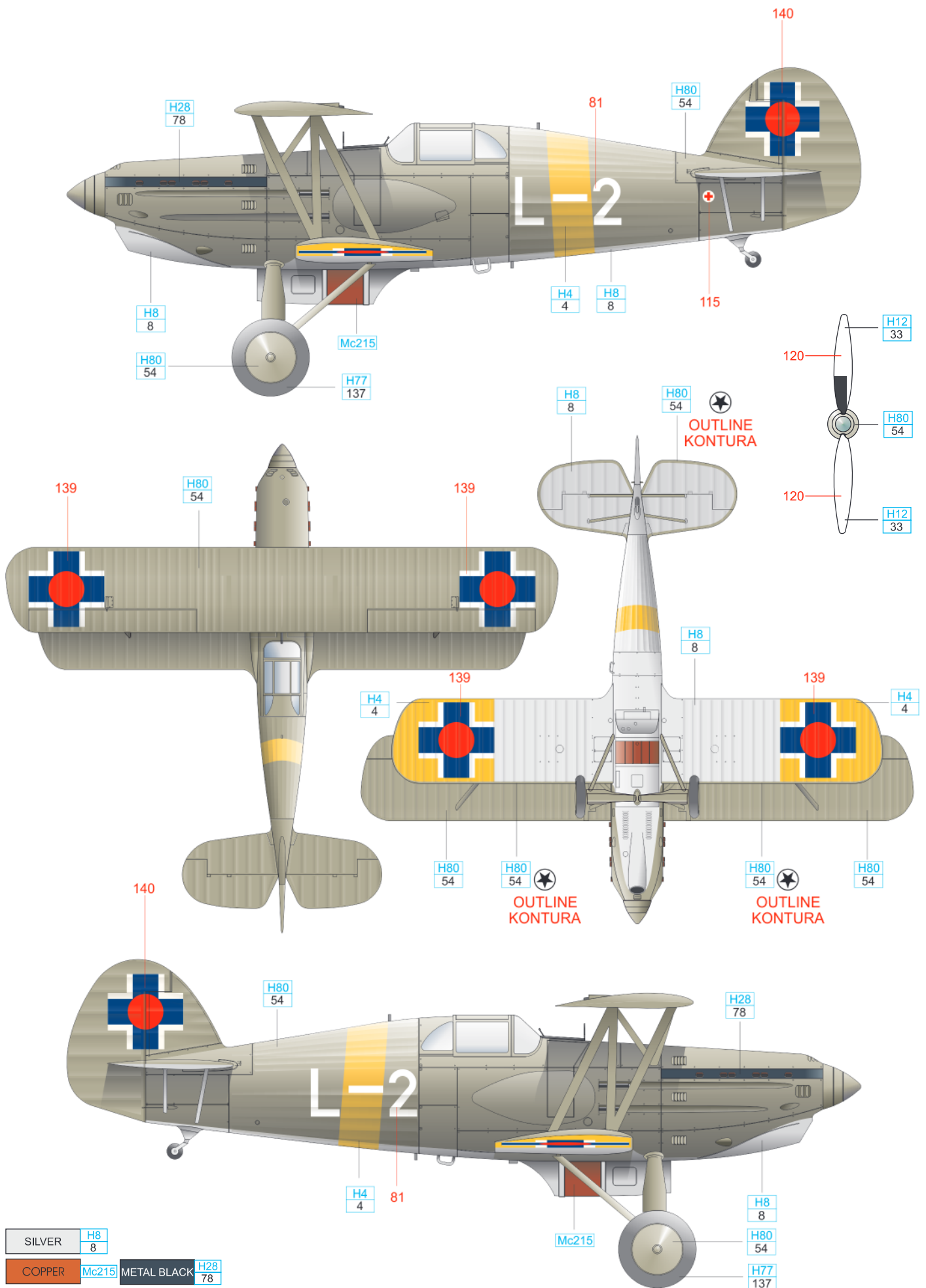

SILVER	H8	METAL BLACK	H28
COPPER	Mc215	TIRE BLACK	H77
KHAKI GREEN	H80	YELLOW	H4
	54	BLACK	H12
			33

16 Avia B.534 4. série, Kombinovaná letka, Tri Duby, září – říjen 1944

The famous B.534.217 flown during Slovak National Uprising is not well documented, only few photos exist. We offer decals for various tactical marking (S-13 & S-18), serial numbers (214 & 217) and national markings (red & blue outline, two options for right side of the rudder, crosses/hills printed separately). The appearance depicted in this page is based on our research.

Známa slovenská B.534.217 není příliš dobře fotograficky zdokumentovaná, k dispozici je pouze několik fotografií. Proto jsme do stavebnice zařadili alternativní obtisky trupového označení (S-13, S-18), sériového čísla (214, 217) a výsostných znaků (s modrým a červeným lemem, dvě verze kokardy na pravou stranu směrovky, separátně tištěné dvouramenné kříže s trojvrším). Zobrazená podoba letounu je výsledkem z našeho výzkumu.

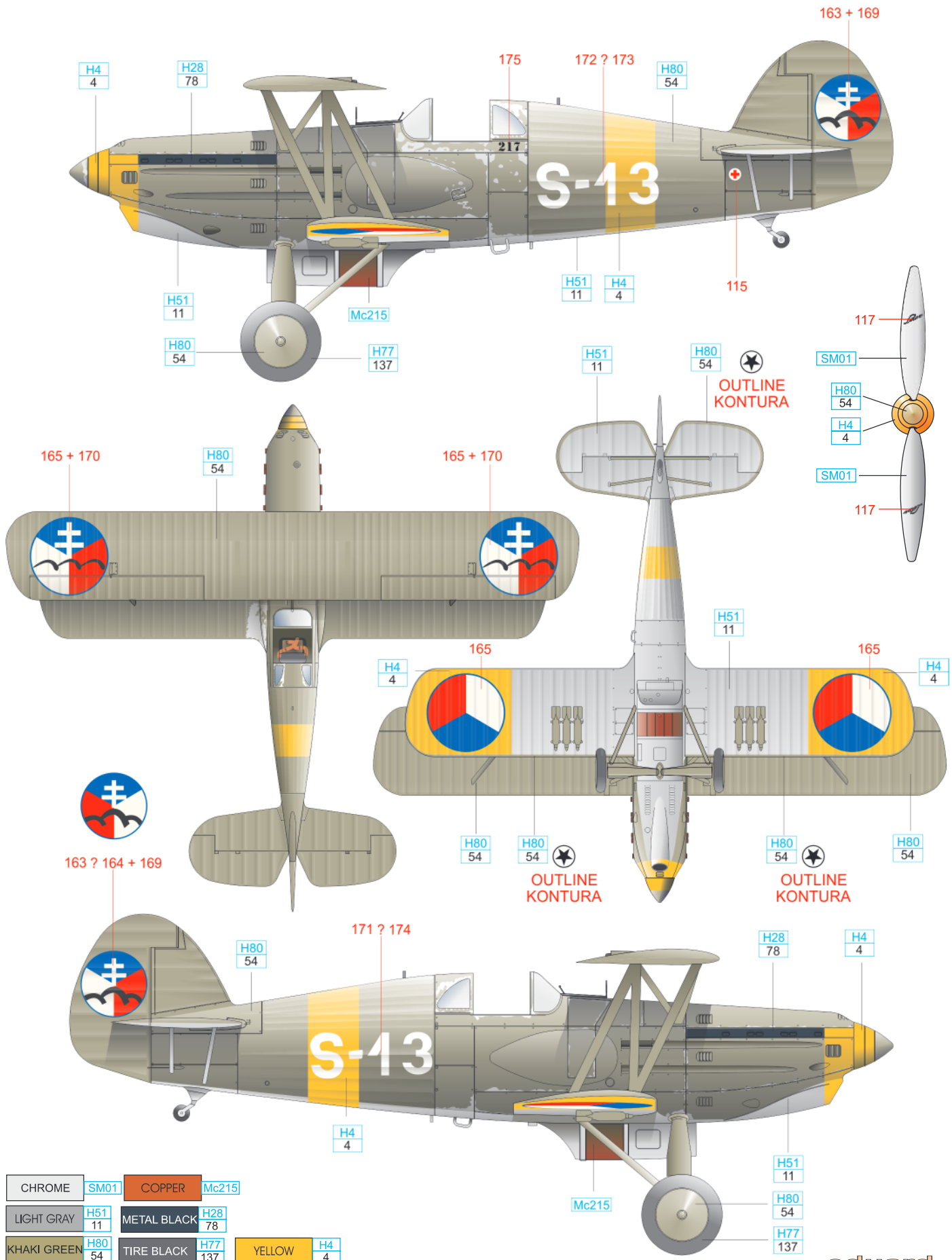

CHROME	SM01	COPPER	Mc215
LIGHT GRAY	H51 11	METAL BLACK	H28 78
KHAKI GREEN	H80 54	TIRE BLACK	H77 137
		YELLOW	H4 4



YELLOW	H4 4	TIRE BLACK	H77 137	BLACK	H12 33	COPPER	Mc215
GRAY	H53 13	LIGHT GRAY	H51 11	GREEN	H303 303	RED BROWN	H47 41

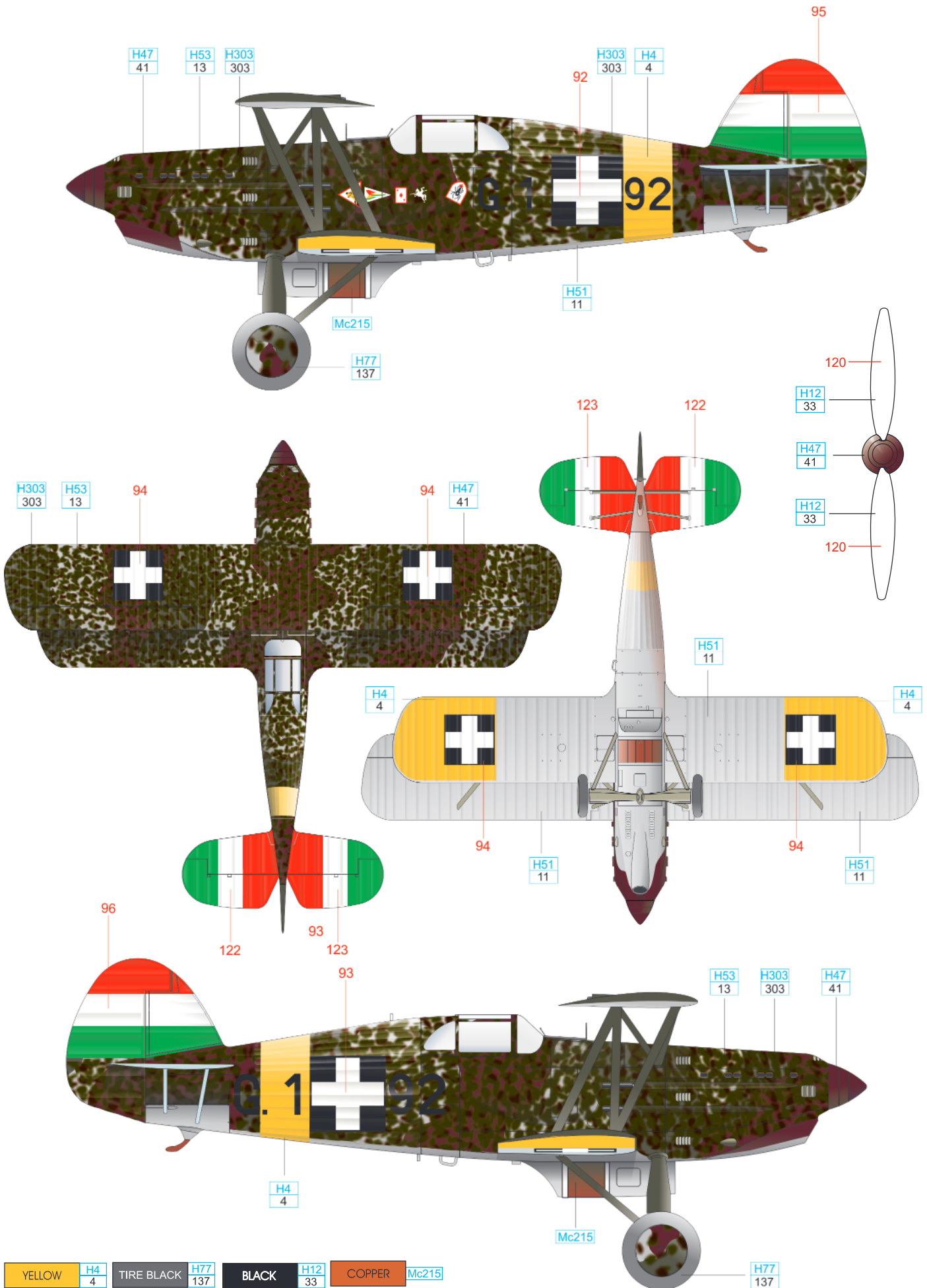

YELLOW	H4 4	TIRE BLACK	H77 137	BLACK	H12 33	COPPER	Mc215
GRAY	H53 13	LIGHT GRAY	H51 11	GREEN	H303 303	RED BROWN	H47 41

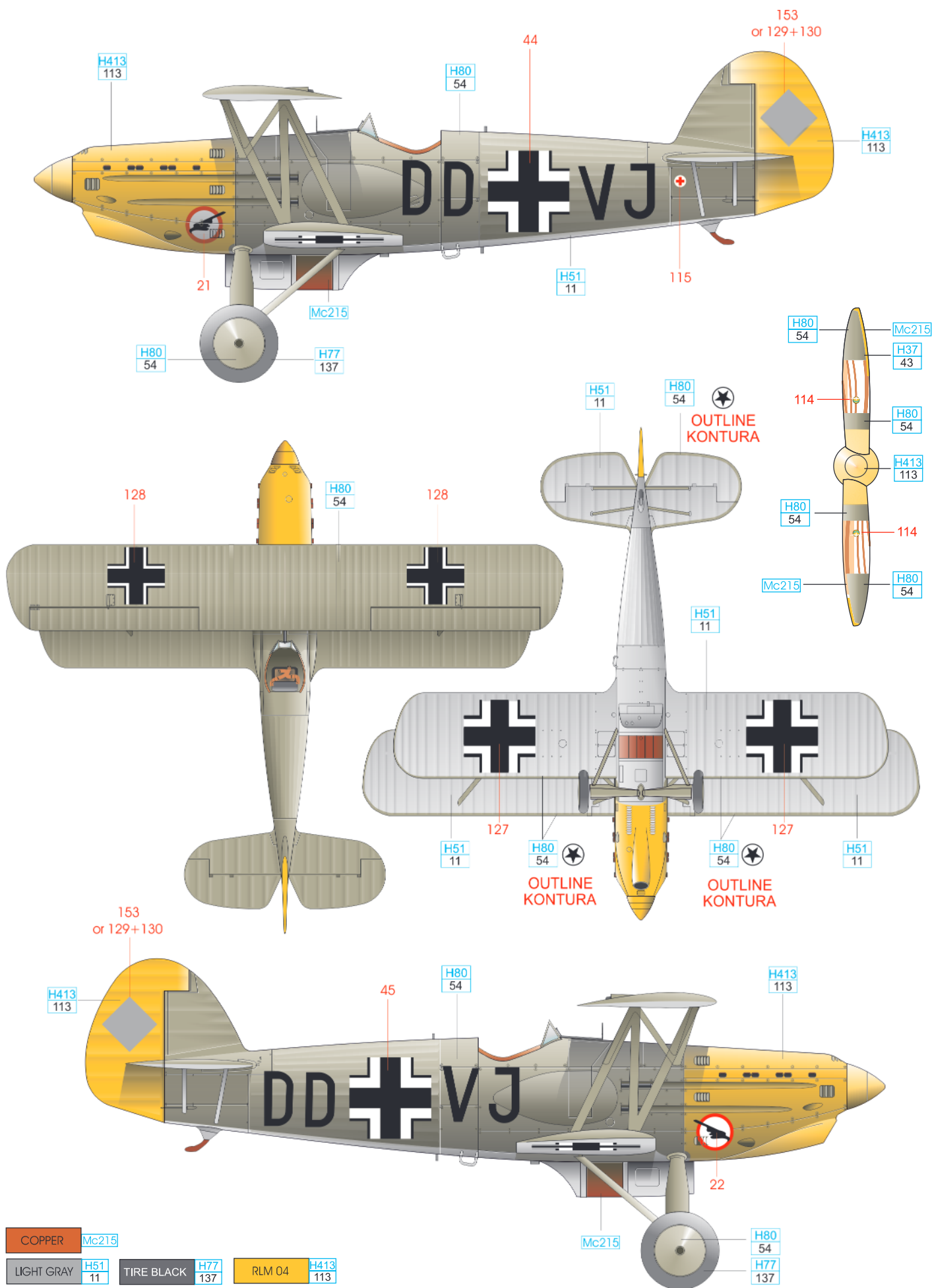

COPPER	Mc215	TIRE BLACK	H77 137	RLM 04	H413 113
LIGHT GRAY	H51 11	METAL BLACK	H28 78	KHAKI GREEN	H80 54
WOOD	H37 43				

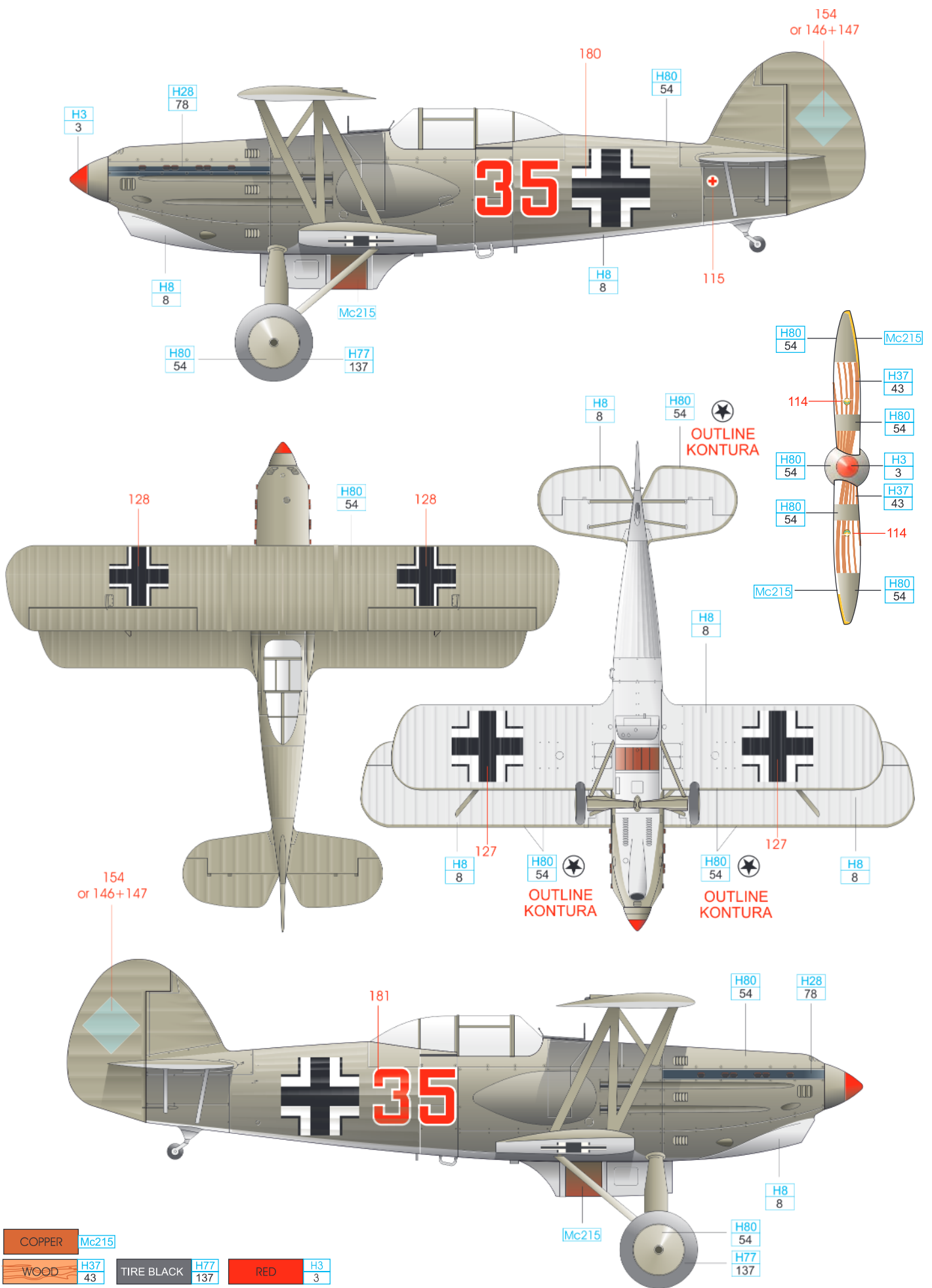

COPPER	Mc215	TIRE BLACK	H77	RED	H3
WOOD	H37	KHAKI GREEN	H80	METAL BLACK	H28
SILVER	H8		54		78

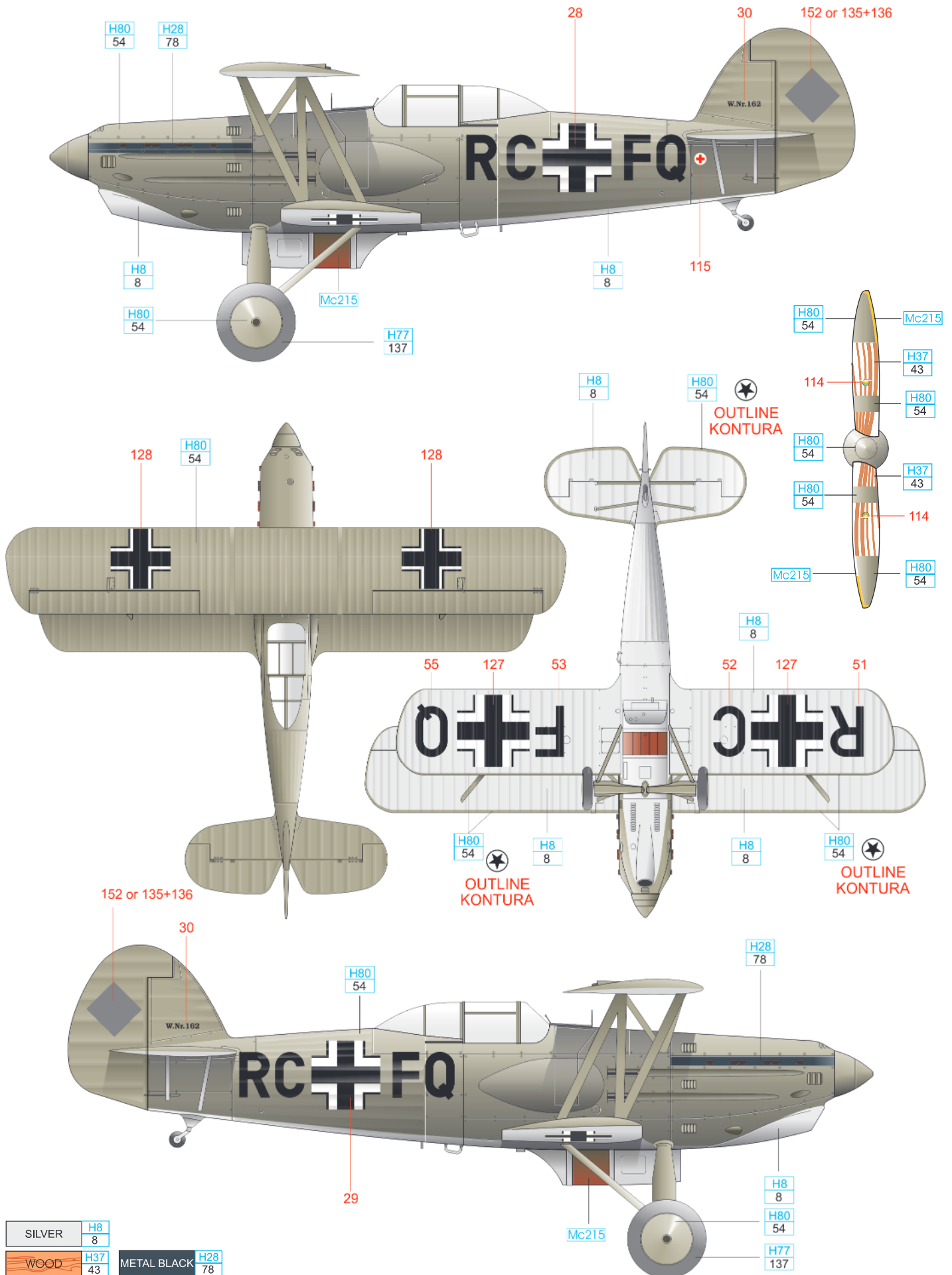

SILVER	H8 8	METAL BLACK	H28 78	COPPER	Mc215
WOOD	H37 43	TIRE BLACK	H77 137		
KHAKI GREEN	H80 54				

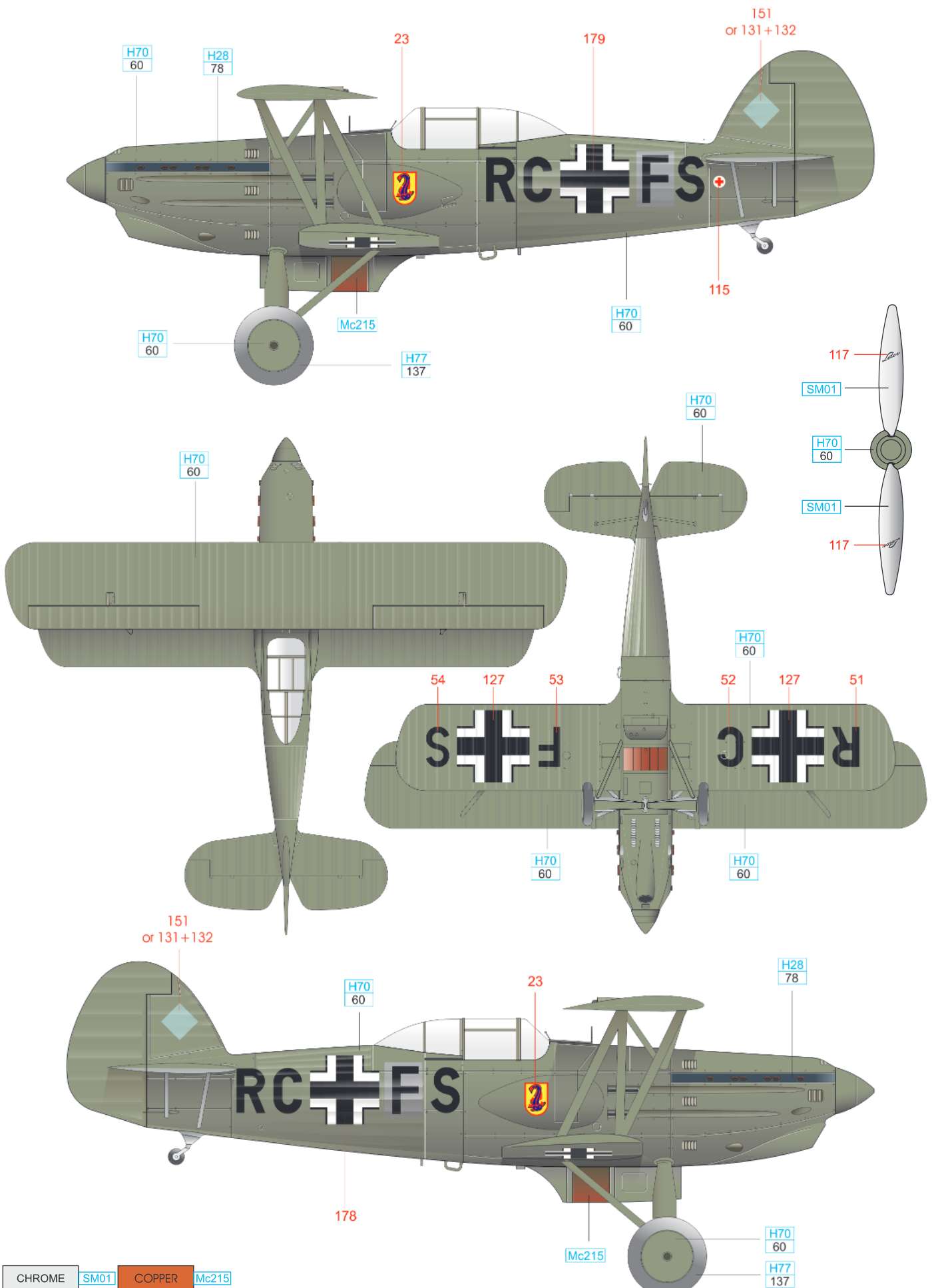

CHROME	SM01	COPPER	Mc215
RLM 02	H70 60	METAL BLACK	H28 78
		TIRE BLACK	H77 137

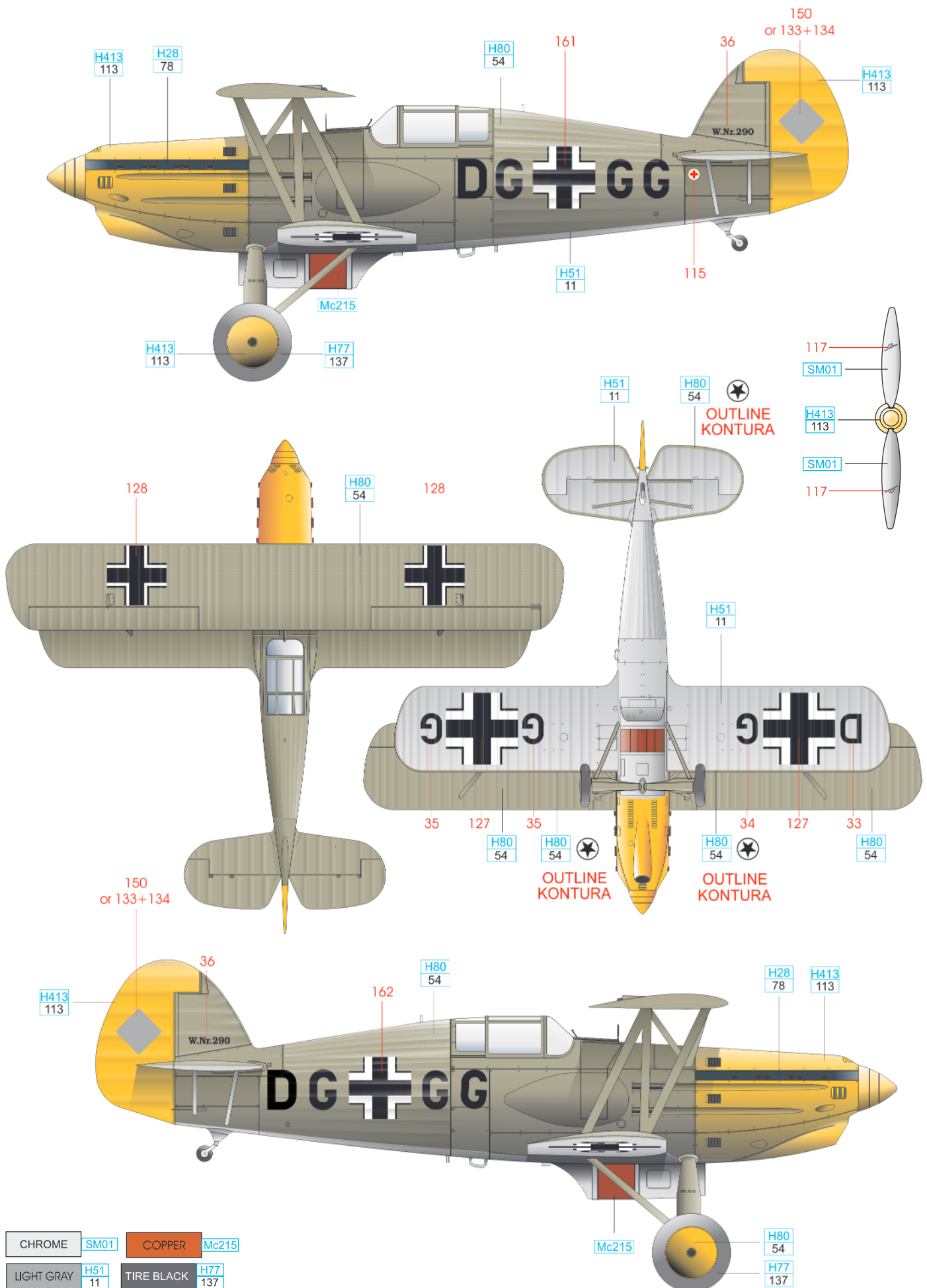

CHROME	SM01	COPPER	Mc215
LIGHT GRAY	H51 11	TIRE BLACK	H77 137
KHAKI GREEN	H80 54	METAL BLACK	H28 78
		RLM 04	H413 113

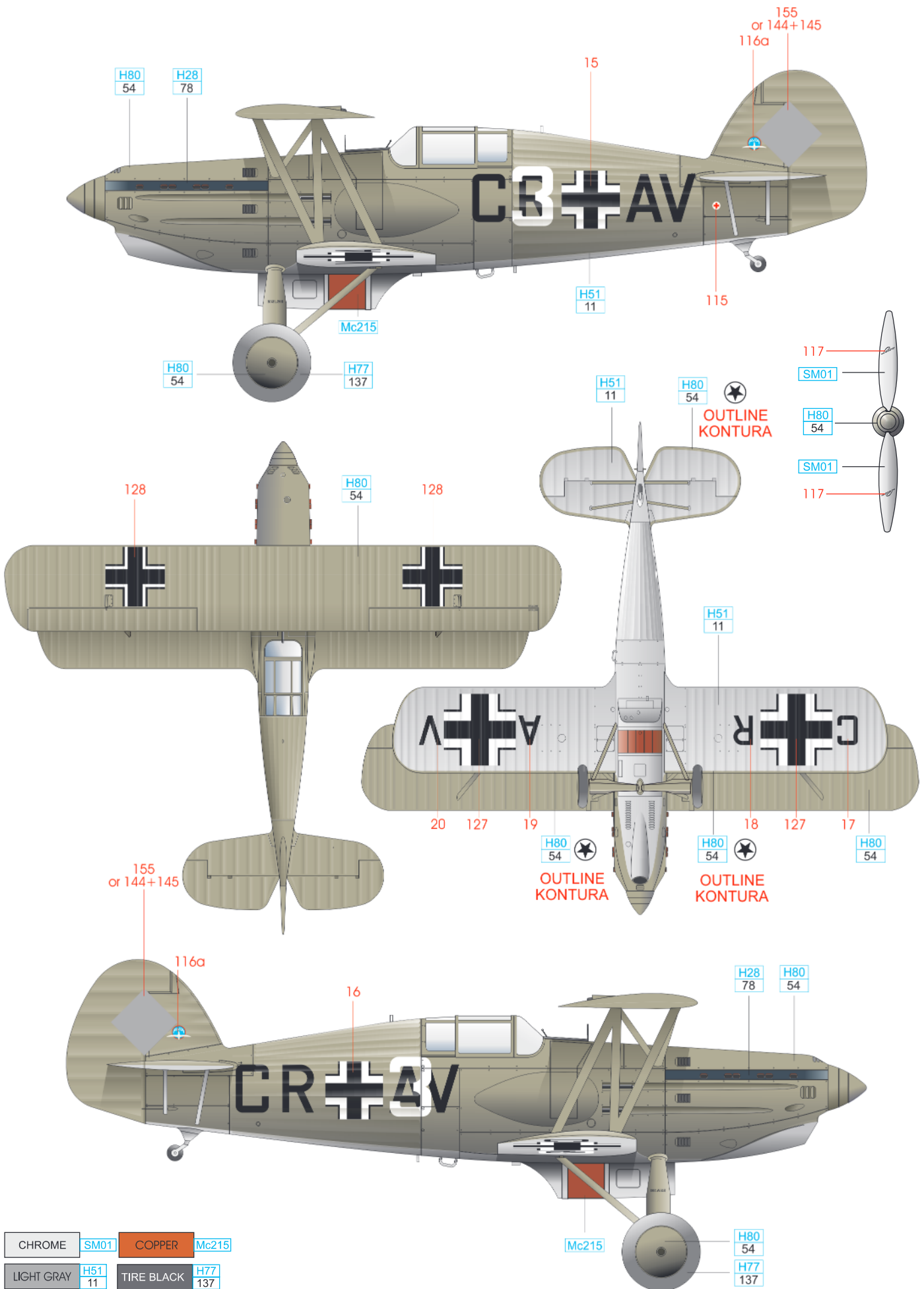

CHROME	SM01	COPPER	Mc215
LIGHT GRAY	H51 11	TIRE BLACK	H77 137
KHAKI GREEN	H80 54	METAL BLACK	H28 78

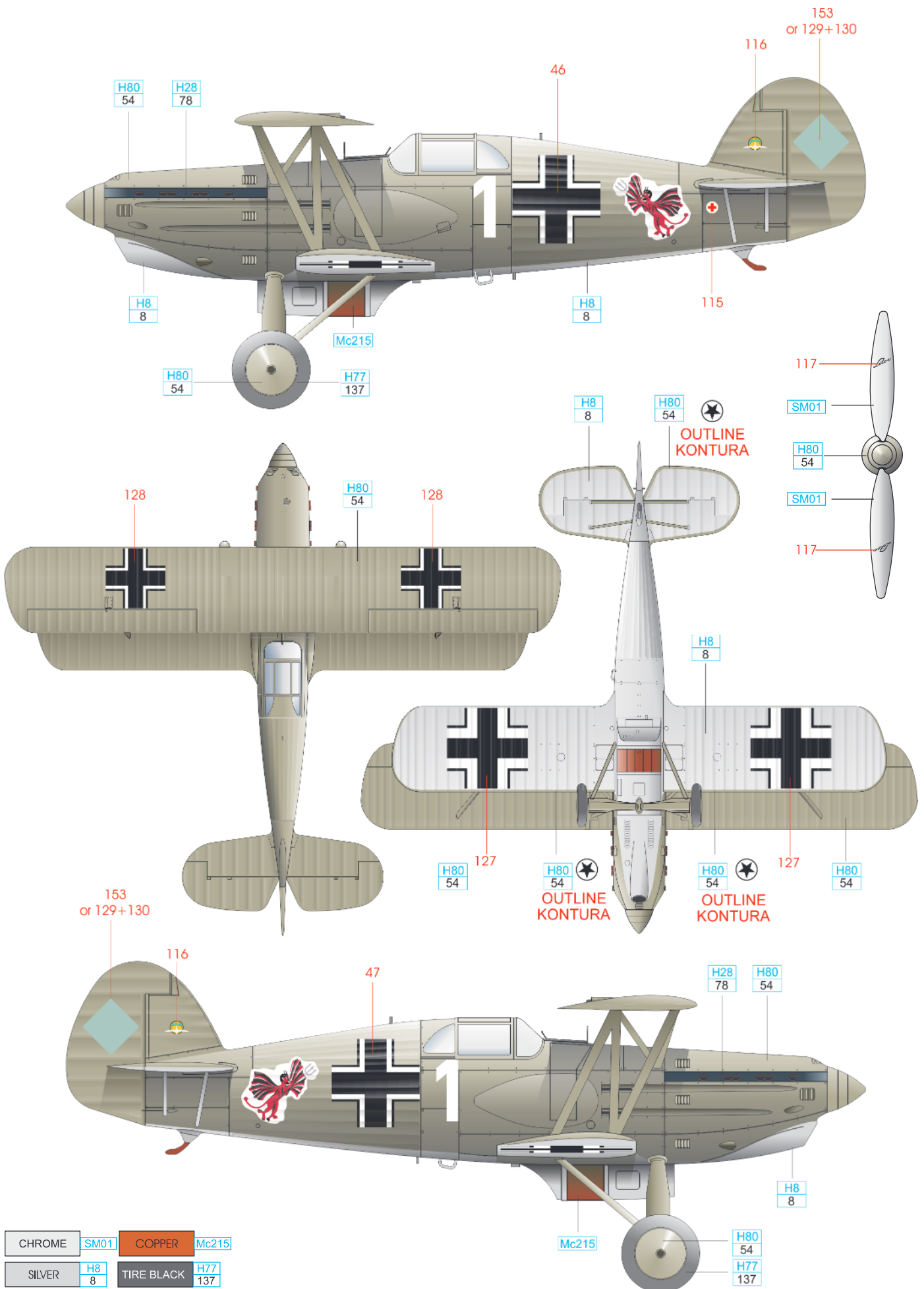

CHROME	SM01	COPPER	Mc215
SILVER	H8 8	TIRE BLACK	H77 137
KHAKI GREEN	H80 54	METAL BLACK	H28 78

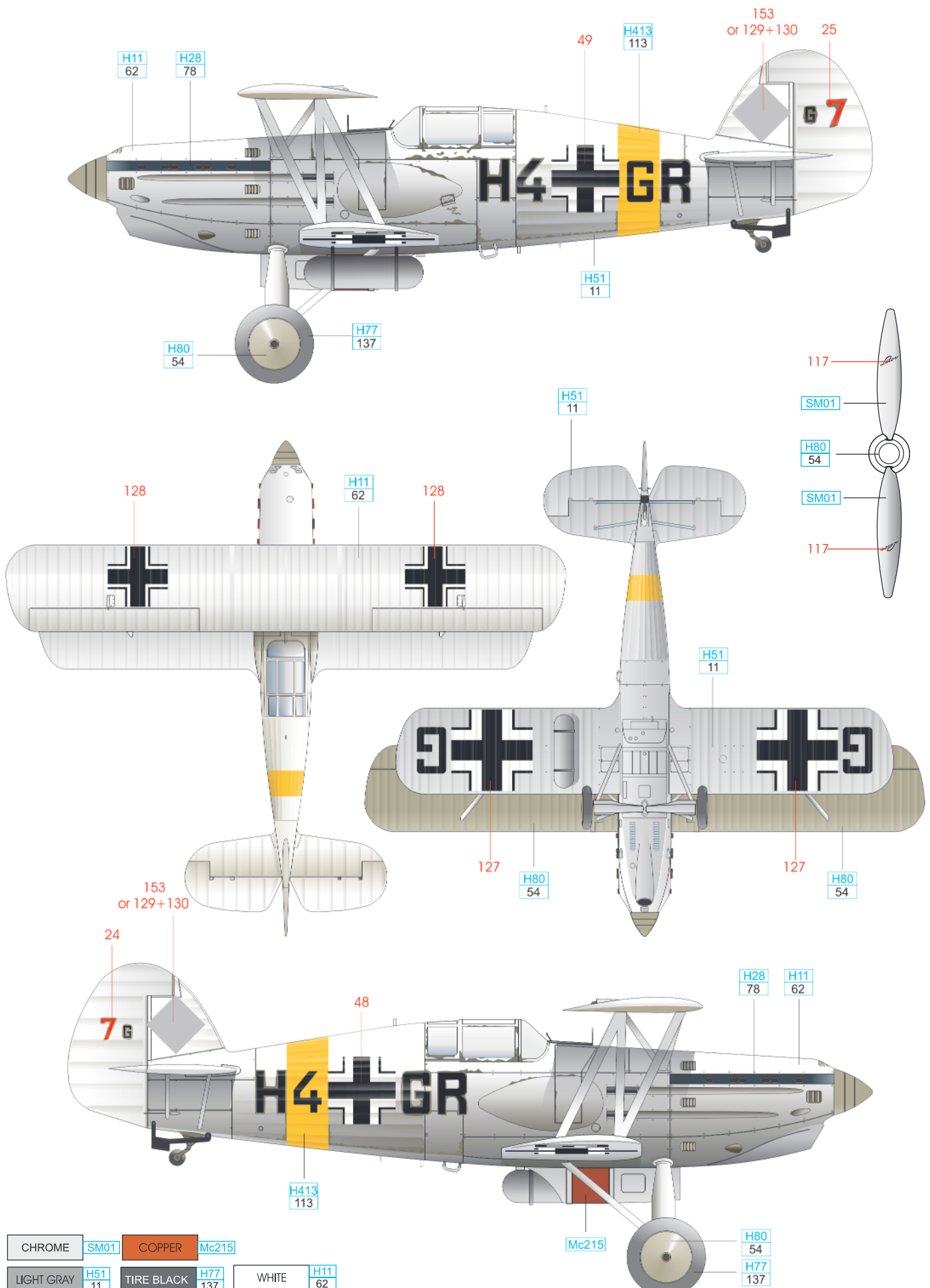

CHROME	SM01	COPPER	Mc215
LIGHT GRAY	H51 11	TIRE BLACK	H77 137
KHAKI GREEN	H80 54	METAL BLACK	H28 78
		WHITE	H11 62
		RLM 04	H413 113

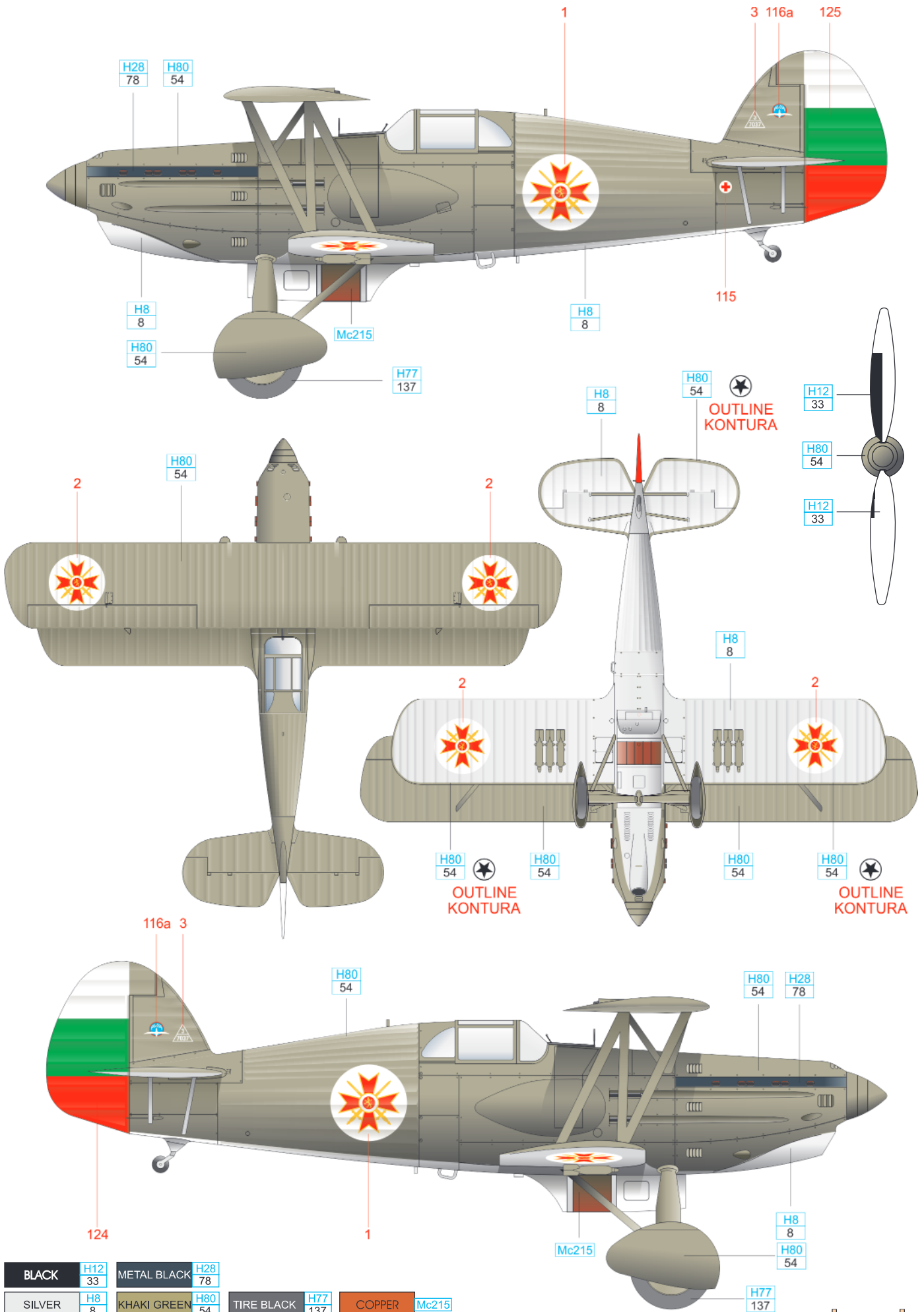

BLACK	H12 33	METAL BLACK	H28 78
SILVER	H8 8	KHAKI GREEN	H80 54
		TIRE BLACK	H77 137
		COPPER	Mc215

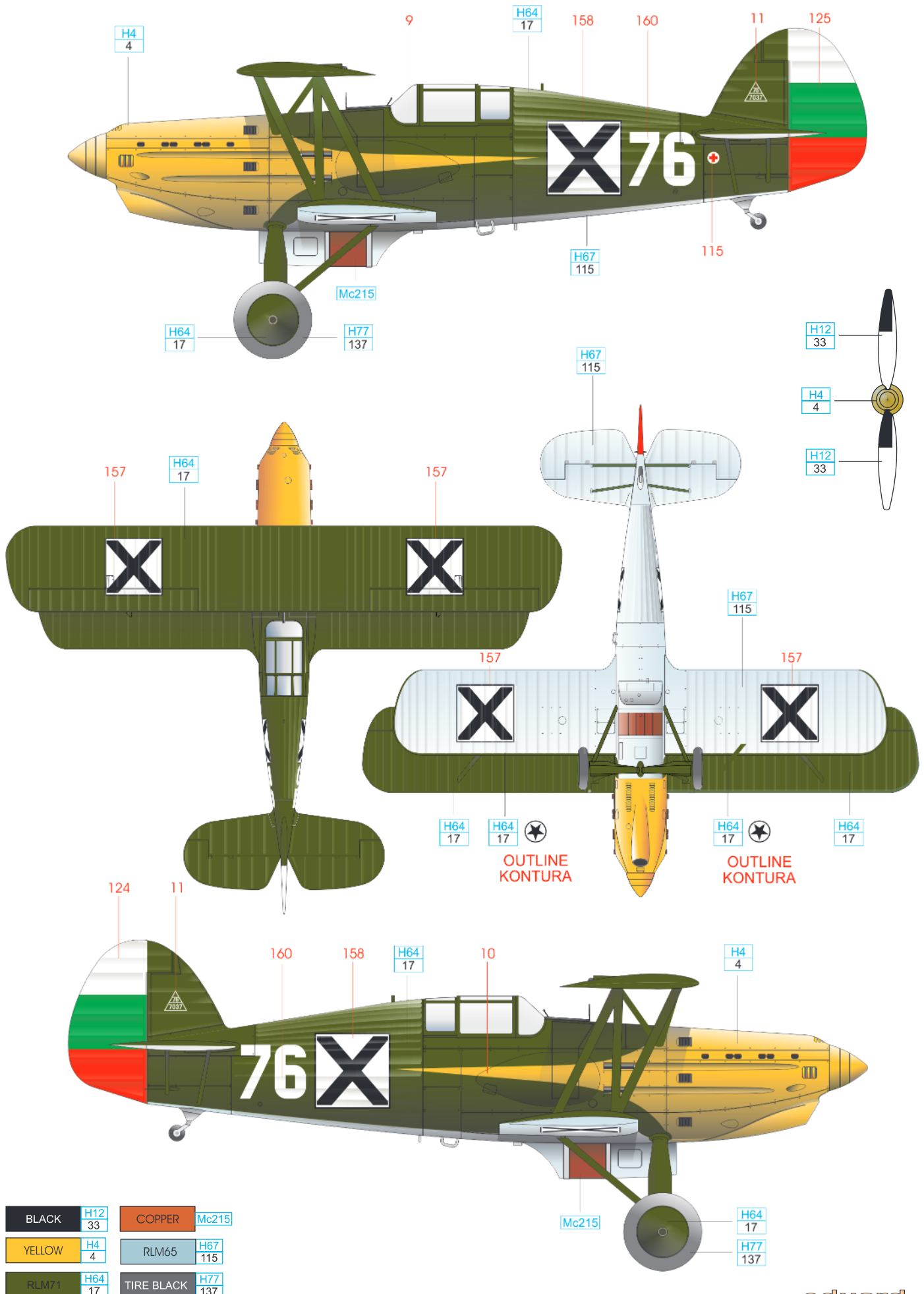

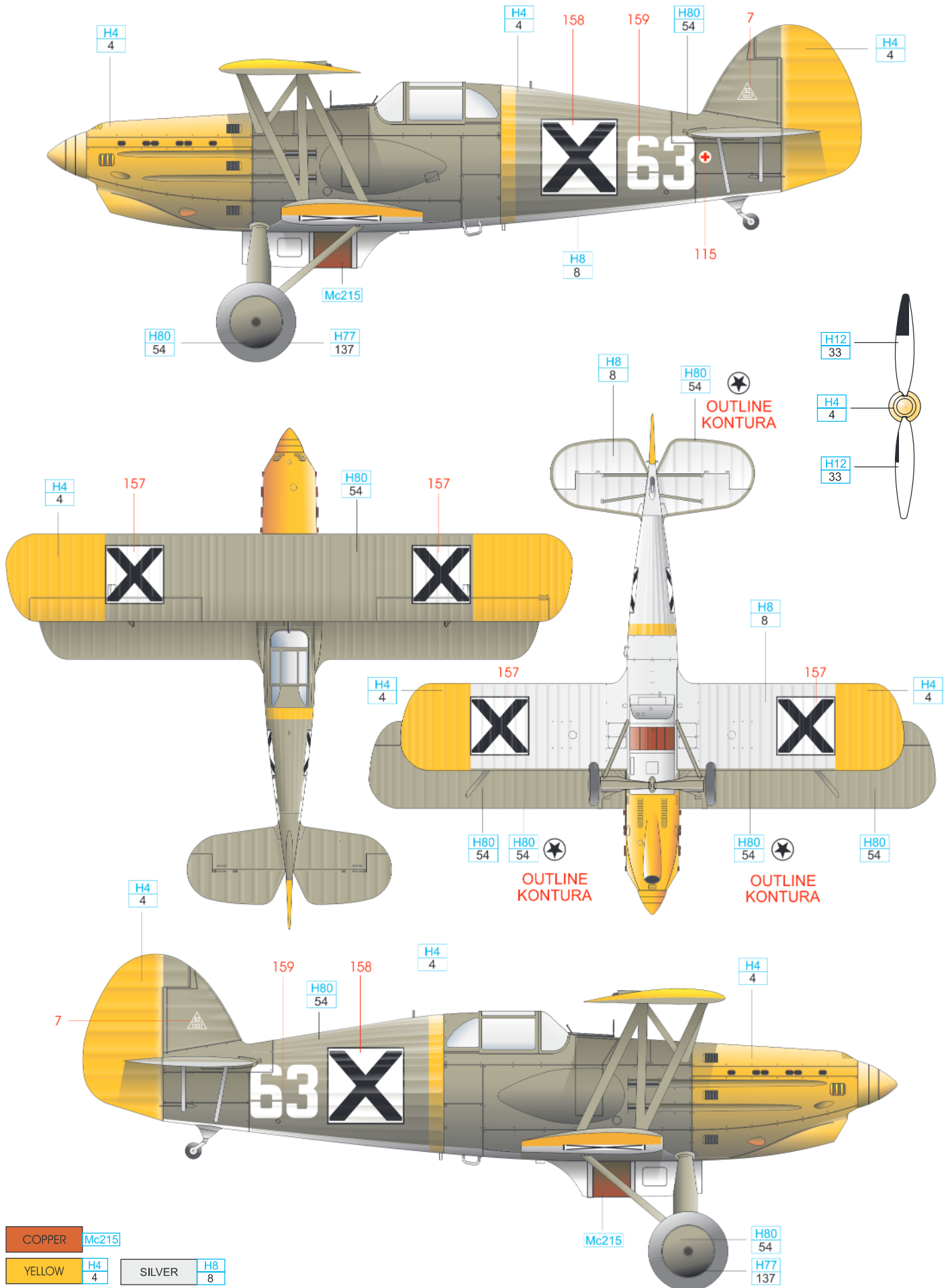

COPPER	Mc215	SILVER	H8 8
YELLOW	H4 4	BLACK	H12 33
KHAKI GREEN	H80 54	TIRE BLACK	H77 137

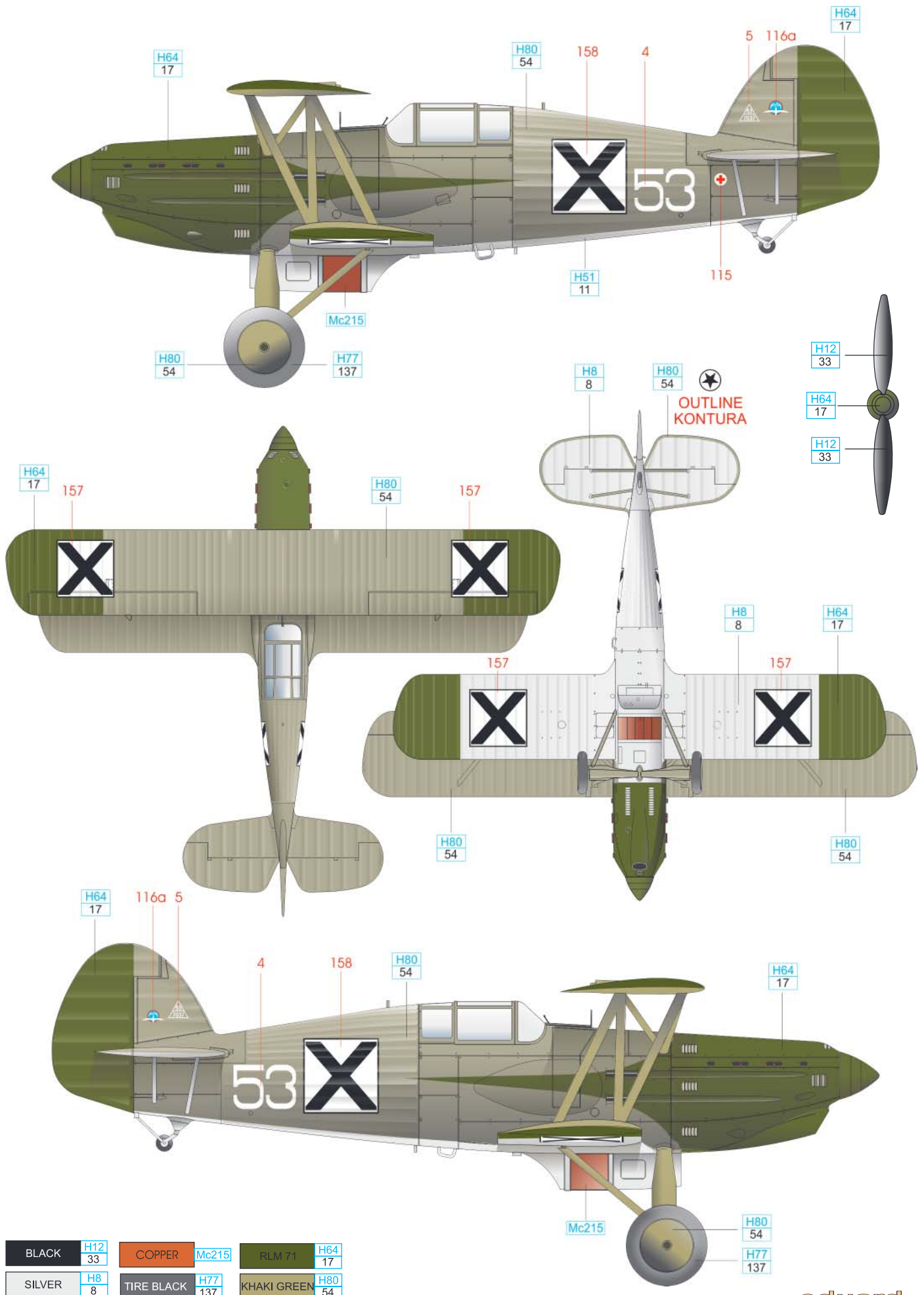

BLACK	H12 33	COPPER	Mc215	RLM 71	H64 17
SILVER	H8 8	TIRE BLACK	H77 137	KHAKI GREEN	H80 54

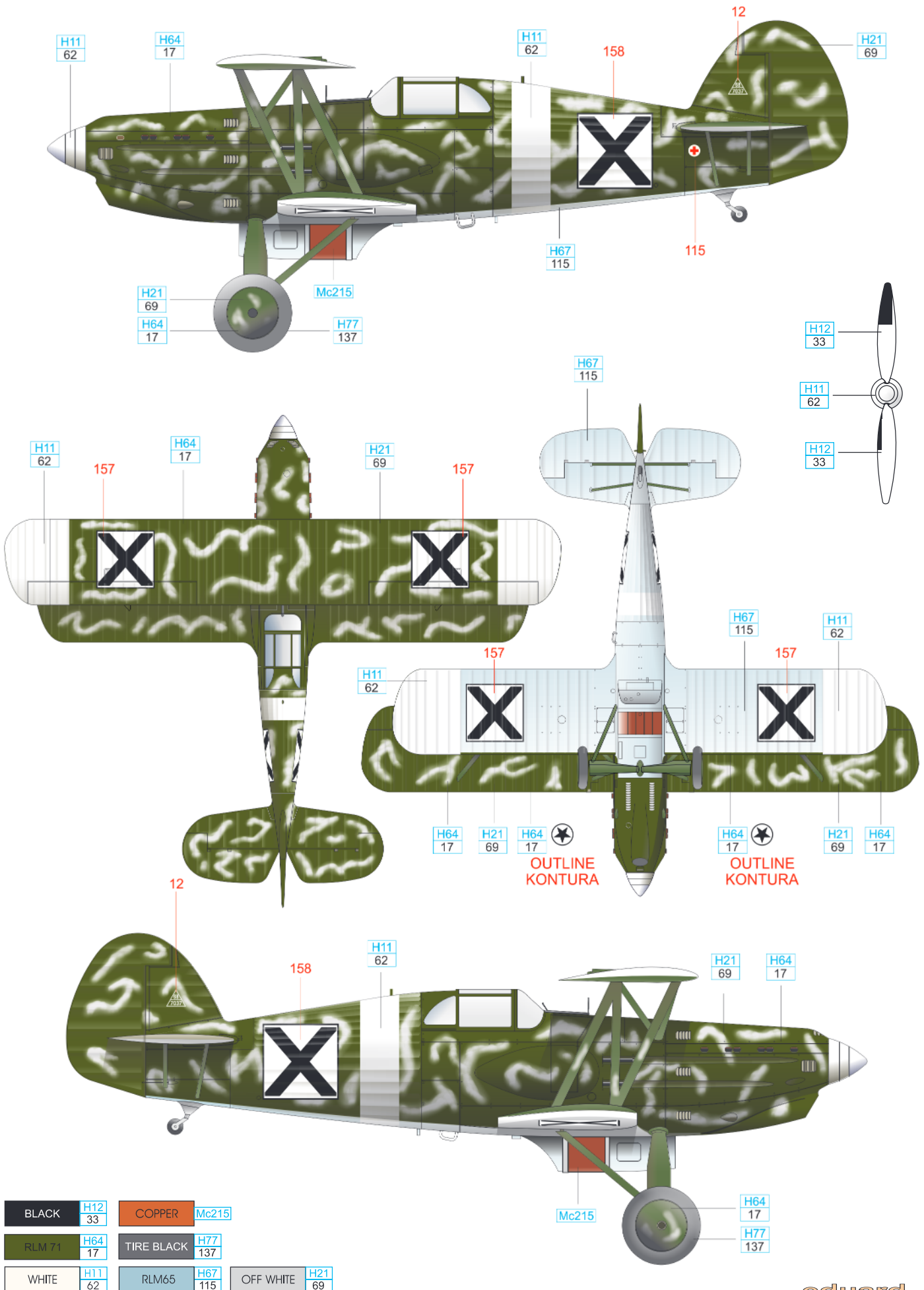

BLACK	H12 33	COPPER	Mc215
RLM 71	H64 17	TIRE BLACK	H77 137
WHITE	H11 62	RLM65	H67 115
		OFF WHITE	H21 69

